

No. 1866

## ASH HANDLING

BY JOHN HUNTER AND ALFRED COTTON, St. Louis, Mo.  
Members of the Society

*Various methods of handling ash are described and illustrated, beginning with early developments on shipboard. The greater part of the paper, however, deals with stationary practice, beginning with rudimentary and progressing to the most modern installations, of which schematic and actual examples are given.*

*Methods of removing ashes from basement boiler rooms are followed by a discussion of the design, construction, and capacity of hopper ashpits, including their doors and water seals. Systems of mechanical conveyance and elevation are described, comprising ash cars, skip hoists and bucket conveyors. Fluid conveyance, as represented by water sluicing and steam-jet conveyors, is discussed in general, and typical examples of both are illustrated and described in detail. Particulars of ash bunkers and settling basins are followed by a discussion of the final disposal of ash.*

**A**SH HANDLING is just as important as coal handling. It is a simpler problem only to the extent that there is less ash than coal, but the coal disappears while the ash accumulates. The ash must be got rid of or the plant will be put out of commission very quickly.

2 The first stage in ash handling is getting the ash out of the fire. This part of the subject does not concern us here, except that the methods employed in either hand or machine firing affect the design of ash-handling equipment, as also does the last stage, the final disposal. The first stage varies all the way from hauling the ashes out of the fire door by hand to washing them out of the gases. The final stage varies from wheeling them out in a wheelbarrow to carrying them away in scows and dumping them at sea. The ash-handling equipment must fit the conditions at both ends.

3 Ash handling was originally accomplished entirely by hand, but with the growth of the size of boiler plants it is now either

---

Presented at the Annual Meeting, New York, December 4 to 7, 1922,  
of THE AMERICAN SOCIETY OF MECHANICAL ENGINEERS.

partly or entirely mechanical. There are three general methods of conveyance in use: air, water, and purely mechanical.

4 The great development of the central electric generating station has compelled operating engineers to give much attention and thought to ash handling. It is only a few years since boilers of 600 hp. were considered large, while today 2000-hp. units are not at all uncommon and some 3000-hp. boilers are in use. Furthermore, while boilers were usually operated at about their rating of 10 sq. ft. of heating surface to the boiler horsepower, they are now commonly operated at twice their nominal rating; and in the larger central stations it is common practice to run them for short intervals at three or even four times their rating. The bearing of this development on ash handling may be strikingly seen when we remember that a 250-hp. boiler running at rating and burning coal with 15 per cent of ash would make 150 lb. of ash per hour; while each 2000-hp. unit at 200 per cent of rating makes well over a ton of ash per hour.

5 The subject may well be divided into three phases: stationary, locomotive, and marine. The locomotive phase may be passed over because of the ability of the locomotive to generate ashes over a wide range of country and dump them in one spot. Marine practice will be dealt with first, partly because it happens that the authors each had early experience in this line, and partly because definite progress in ash handling was first made on ship-board.

#### MARINE PRACTICE

6 Practically all coal-fired ships are hand-fired and hand-cleaned. No mechanical stoker has yet met the conditions sufficiently to warrant even an extended trial. The old way was to load the ash in buckets which were lifted through the ventilators by a steam "ash hoist" on deck. The noise was objectionable on passenger boats, as also was the dust flying all over the ship when dumping overboard.

7 About thirty years ago the engineers of one of the leading transatlantic steamship companies adopted the ash ejector. This was a simple arrangement in which a hopper provided with a water-tight lid was placed on the boiler-room floor, with a pipe leading from the hopper upward and through the ship's side above the water line. The ashes were dumped into the hopper and the lid

closed and clamped. Then water under as much as 200 lb. pressure was admitted to the hopper through a tapered nozzle, discharging the water and ashes overboard by a siphon action. This method was a vast improvement over the old ash hoist, and was much easier for the men, who would handle the ashes in half the time. Ash ejectors have been much improved and are now extensively used in passenger ships. Fig. 1 illustrates one of these ash ejectors as made by the M. T. Davidson Company, of New York.

8 In passenger ships it is often objectionable to discharge ashes at high velocity from the ship's side above the water line, as this frequently results in ashes flying over the deck. It is not

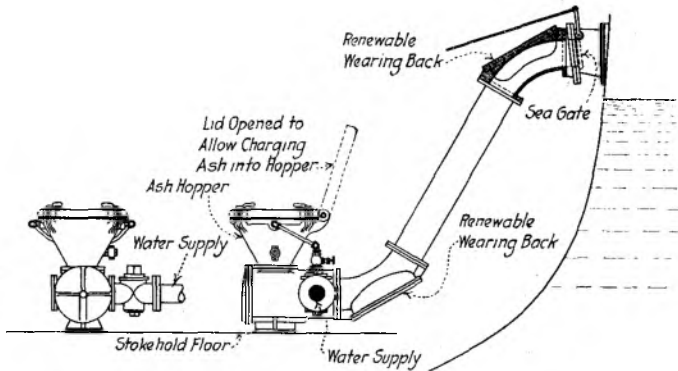

FIG. 1 MARINE ASH EJECTOR, OPERATED BY WATER

permitted when in dock or when small boats are near. These difficulties are met by Stone's underline ash expeller which is illustrated in Fig. 2, whereby the ashes are discharged vertically downward through the ship's bottom. The method of operation is that of the water ejector having a water motive jet and an auxiliary water jet to drive the ashes from below the receiving grating into the ejector entrance. The passage from the ash-receiving grating to the ejector is closed by a valve attached to a piston operated by the pressure at the throat of the venturi portion of the ejector. When this valve is being closed, a supply of water is arranged to wash the valve and its seat clear of ash. Modified plug cocks are also provided for emergency closure in addition to the automatic valve.

9 Some of the incidental advantages of this system are interesting. Since the ashes are discharged thoroughly wet and well below the water line, they do not leave a spoor or trail of ashes on the surface which would convey information to an enemy in war time. Also, as each ejector can discharge 650 tons of water

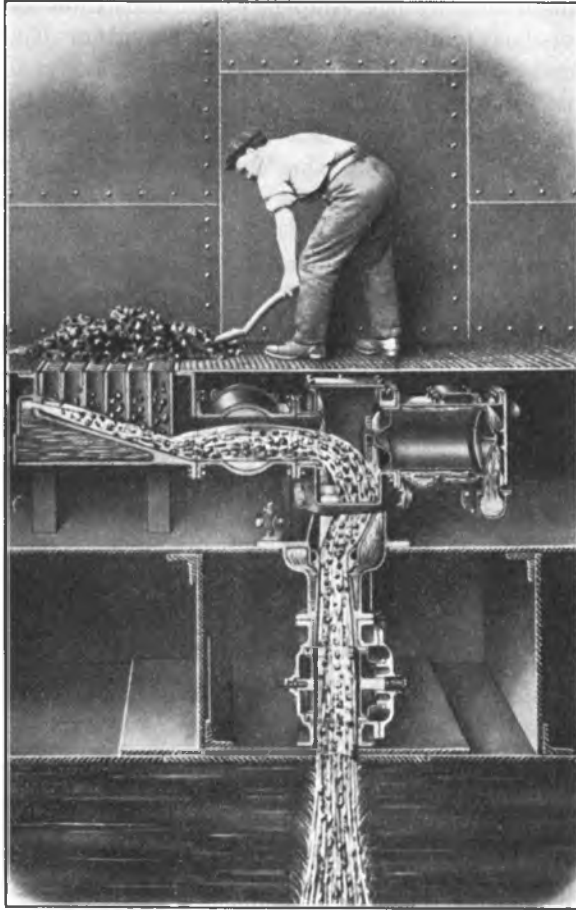

FIG. 2 STONE'S MARINE ASH EXPELLER, OPERATED BY WATER

per hour, they can be used as salvage pumps to overcome serious leakage. The British battleship *Marlborough* was torpedoed as she was going into action at Jutland, and enough of the ship's side was ripped off from the bilge to above the water line to expose two

watertight compartments. As the explosion sprung the bulkhead, between 300 and 400 tons of water per hour poured into the forward stokehold. Ordinarily such a leak would have meant the almost certain loss of the ship; but by using the ash expeller as a salvage pump the vessel kept her station and continued fighting throughout the battle. Not only that, but she was kept afloat by means of the ash expeller for six days until she could be docked. The authors are indebted to the McNabb Company, of Bridgeport, Conn., for the illustration forming Fig. 2, and for particulars of the incident just related.

10 The steam-jet ash conveyor is used to a considerable

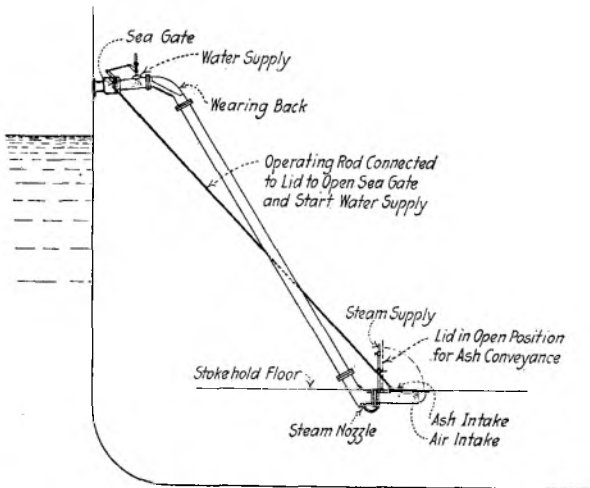

FIG. 3 MARINE ASH EJECTOR, OPERATED BY STEAM

extent on harbor tugboats. Such an installation is that of the Victor Engineering Company, of Philadelphia, which is shown in Fig. 3. This type of conveyor will be more particularly described when dealing with stationary practice. The objection to its use in ocean-going steamers is the loss of water, since the steam used is discharged to the atmosphere. All water lost to the atmosphere by the open discharge of steam, such as from safety valves, whistle, leaks, etc., must be made up by the use of sea water; and this sea water must be purified either in the boilers by concentration and blow-down as was the old practice, or by the modern method of distillation. Therefore the amount of "make-up" required must

always be kept as low as possible, with the result that very few steam-consuming auxiliaries which do not exhaust into the condenser can find a place on ocean-going steamers. Harbor tugs carry fresh-water tanks which are easily and regularly replenished, and even their main engines are therefore frequently non-condensing. There is no objection to the use of steam-jet ash conveyors in these cases, provided their use is not forbidden by harbor rules. It will be understood that this objection has no reference whatever to the

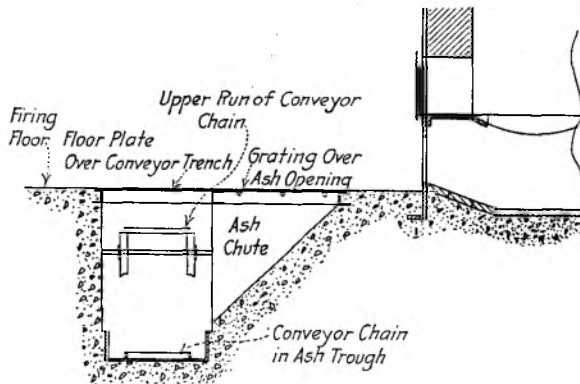

FIG. 4 CHAIN AND CROSS-BAR CONVEYOR

amount of steam used thermodynamically, but simply that it represents so much fresh water lost.

#### STATIONARY PRACTICE

11 Except that there are several standardized types of conveyors, classification of methods of ash handling is not convenient and would serve no useful purpose. Each problem must be considered entirely according to its particular circumstances. The methods of offering the ash in the first place, the general conditions to be met, and the final disposition are all so varied and the possible combinations of each are so numerous that each installation is different from others in some respects. Therefore no real classification will be attempted, but several different schemes and installations will be fully described. It is believed, after very mature consideration, that this will be the most satisfactory method of dealing with the subject, and will be most helpful to those con-

fronted with this problem. Component parts of installations illustrated may be taken and combined to meet most requirements; but it must be remembered that to make a successful installation in a large modern plant, considerable experience and shrewd judgment are very necessary.

12 The most rudimentary method is that in which the ashes are hoed out of the fire doors and ashpits on to the firing floor and shoveled into wheelbarrows which are dumped outside the boiler room, either to fill up depressions or to be carted away. In some cases the ashes are shoveled into industrial railway cars, which are then pushed to the dumping point. In some existing plants a

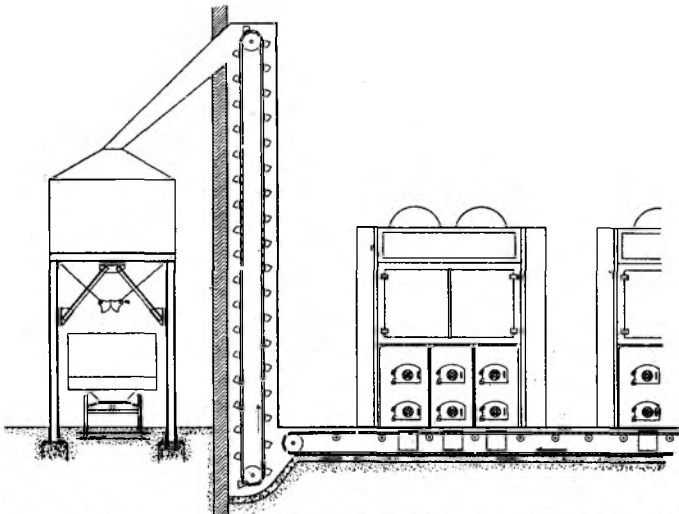

FIG. 5 CHAIN AND CROSS-BAR CONVEYOR WITH BUCKET ELEVATOR AND ASH BUNKER

basement is out of the question, and even if a change were made to stoker firing, the ashes would still have to be hoed out of the ashpit. But the wheelbarrow can be replaced by either a mechanical or air conveyor.

13 Fig. 4 is a cross-section of a block-chain conveyor running in a trench under the firing floor. The ashes are hoed on to the grating, through which they fall down the chute to the bottom of the trench. They are then drawn along by the chain, discharging into a bucket elevator as illustrated in Fig. 5, or on to an inclined chain conveyor carrying the ash into an elevated storage hopper.

14 Where there is a plentiful supply of water, a flume may be carried along under the firing floor and the ashes raked into it through openings. This is a very simple method, but it is seldom that a natural water supply and sufficient fall from the plant are available to adequately dispose of the ashes.

15 The problem is more complicated when the boiler room is considerably below the ground level. In such cases there will seldom be a basement below the boiler room, partly on account of the expense of further excavation, and often because of difficulties with building foundations and with water. Good examples are the boiler rooms of office buildings, hotels, etc., where the boilers are generally a considerable distance below the street level and the building is closely surrounded by streets and other buildings. Whatever the final disposition may be, the ashes are invariably removed from the vicinity in motor or horse-drawn trucks. Here, the important consideration is principally that of hoisting the ashes from the boiler room to the street. The crudest method is to load the ashes into ash cans and hoist them by hand-operated block and tackle to the street. This entails high labor cost.

16 In the isolated heating plants of the Union Electric Light and Power Company in St. Louis, exactly this problem existed. It was solved in the following very simple manner with some saving in labor: The ash trucks were equipped with a davit just like a regular boat davit on shipboard. A small winch with a 4-in. barrel geared to a  $\frac{1}{4}$ -hp. electric motor was mounted at the side of the truck. A  $\frac{3}{16}$ -in. steel wire rope was attached and wound on the winch barrel, and passed through a pulley block hanging from the head of the davit with a hook at the free end. The davit was simply a length of  $1\frac{1}{2}$ -in. pipe bent to shape with the head end flattened to facilitate bolting on the lug of the pulley block. Current for the motor was conveyed by a flexible cord from a socket in the plant and snapped to the motor when the ash truck arrived. Opening the sidewalk cover, the hook was dropped and the first ash can attached, quickly hoisted to the davit head, the davit swung around and the ash can dumped into the wagon, and then returned to the basement. With this cheap and simple rigging the truck was quickly loaded, the flexible cord disconnected from the motor, the sidewalk cover closed, and the truck driven away. The whole operation was completed in a few minutes with greatly increased economy in handling.

17 In some instances the air conveyor (the so-called steam-jet conveyor) has been used very advantageously in hospitals, hotels, and office buildings in crowded parts of cities, but it is not always applicable. Unless certain precautions are observed, such as connecting the air discharge into the chimney, the noise may entirely prevent the use of the system.

18 Another method is the "post box" elevator illustrated in

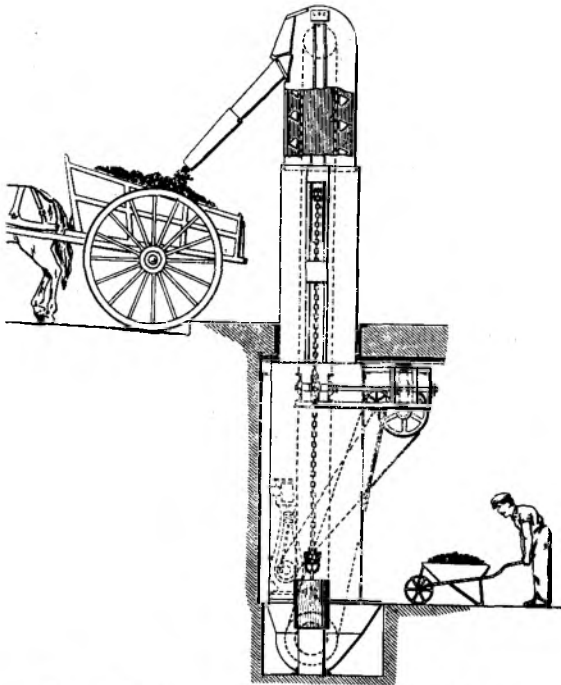

FIG. 6 TELESCOPIC SIDEWALK BUCKET ELEVATOR

Fig. 6. The ashes are stored in the boiler room until the arrival of the ash truck. The elevator, which is of the bucket type, has a telescopic housing which is pushed up through the sidewalk opening and the chute extended to discharge into the truck. When the truck is filled and the elevator stopped, it is withdrawn below the sidewalk and the cover closed over the opening. The casing of the elevator is telescopic to allow of its retraction below the sidewalk, and the bucket chain is so designed as to allow the slack to pile up in an orderly manner at the bottom without becoming entangled.

19 Where conditions allow, an ash-storage hopper may be contrived within the building and a closed ash chute temporarily extended over the sidewalk to the ash truck. The storage hopper may receive ashes from a bucket car and whip hoist, a bucket elevator, or an air conveyor. It is not often that this method can be employed. The purpose of the building may entirely prevent

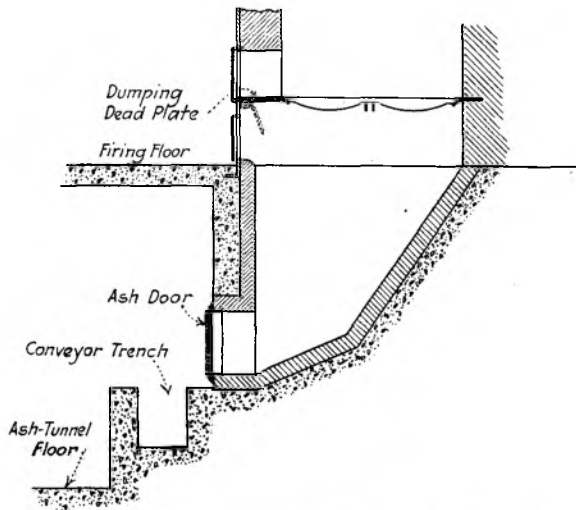

FIG. 7 HOPPER ASHPIT FOR HAND-FIRED FURNACE

the use of such a hopper, and the temporary extension of the ash chute over the sidewalk would not be permitted in the better or more crowded streets.

20 The first operation where labor can obviously be saved is in avoiding hoeing and shoveling ashes at the outset. This leads naturally to a consideration of the hopper ashpit.

#### HOPPER ASHPITS

21 The hopper ashpit is regular practice in the modern plant. Its size and general design will depend primarily upon the manner in which the ashes flow into it, the method of removal, and also upon the system of draft. The design begins at the top to suit the stoker.

22 In hand-fired, forced-draft anthracite plants the top of the hopper will conform to the whole grate area. With stationary grates fine ash is falling constantly over the whole area. As the fires are hand-cleaned, a dumping deadplate will keep the ash away from the firing floor and allow it to fall directly into the hopper, the forced draft being temporarily shut off. With dumping grates the ash will also fall from most of the grate surface. The ashpit will most probably be a storage hopper, which will be emptied

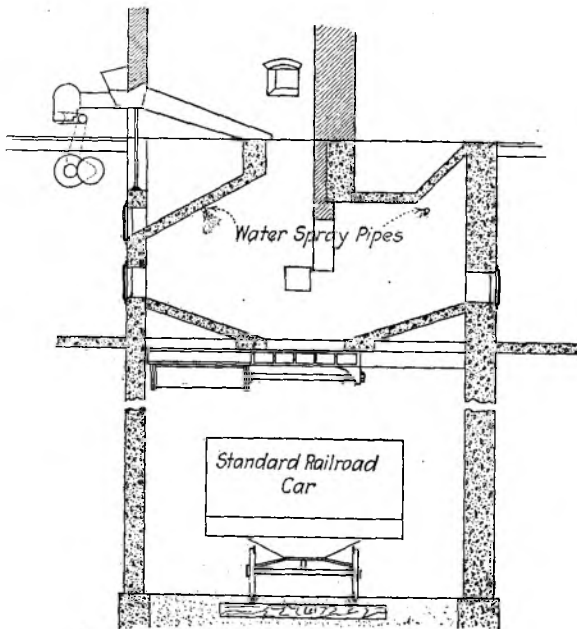

FIG. 8 LARGE-CAPACITY HOPPER ASHPIT

at intervals with the forced draft shut off. Large capacity is necessary because of the high percentage of ash in this fuel. The discharge door must be airtight to avoid increasing the cost of generating the forced draft and the possible reduction of ashpit pressure's lowering the boiler capacity. If it can be dumped directly into railroad cars, the basement being deep enough for this purpose, the hopper can be quickly dumped through bottom doors. Where conveyors are installed it is usual to use a side door and work the ashes out gradually into the conveyor to avoid choking it, as would happen with a straight dump. Fig. 7 illustrates a

layout of this kind. The conveyor will occupy the trench in front of the ash door. It may be mechanical, bucket or chain, or air or water, and is therefore shown schematically only.

23 With forward-travel underfeed stokers, chain-grate stokers, front-feed inclined stokers, and others the ashes are dumped at the rear of the furnace and the top of the hopper will be the width of the fire but of small dimension from front to rear to accord with the stoker dump. This reduces the capacity for storage as is seen by examining Fig. 9. Where large storage is imperative, the ashpit

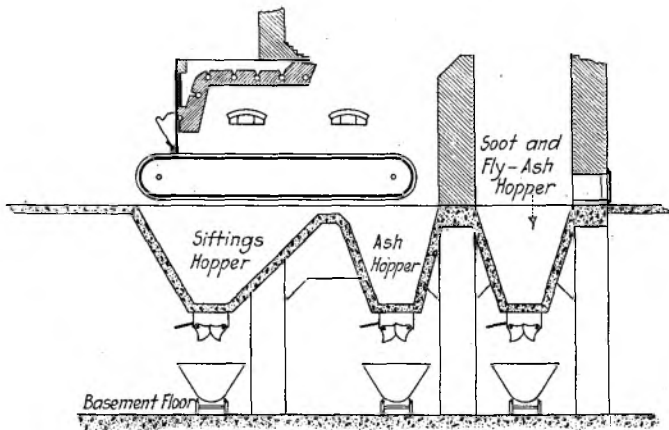

FIG. 9 HOPPERS FOR ASHES, COAL SIFTINGS, AND SOOT

may be designed as in Fig. 8, which is drawn from an illustration appearing in *Power* of January 17, 1922. Owing to the flatness of the bottom, some hand labor is necessary to effect complete discharge when desired.

24 With chain-grate stokers a hopper should also be provided for fine coal which sifts through the grates before ignition. Such an arrangement is shown in Fig. 9. This coal is dumped into some means of conveyance to be returned to the stoker coal hoppers.

25 Side-travel underfeed stokers dump at each side of the wind box for the whole depth of the fire. Hopper ashpits for this type of stoker may therefore have greater storage capacity since the top of the hopper extends to the front of the boiler. Fig. 10 illustrates an ashpit of this kind. In the Combustion Engineering Company's Type E stoker a valve is provided to admit

forced draft to the ashpit in order to burn out the ash more completely before dumping, and therefore the ashpit dump doors should be reasonably airtight.

#### ASHPIT CAPACITY

26 In discussing the amount of storage required, it will be noticed that there are frequently two places where the ash is stored: in the ashpit, and in the elevated ash bin if there is one. In some instances very little capacity may be sufficient, owing to storage

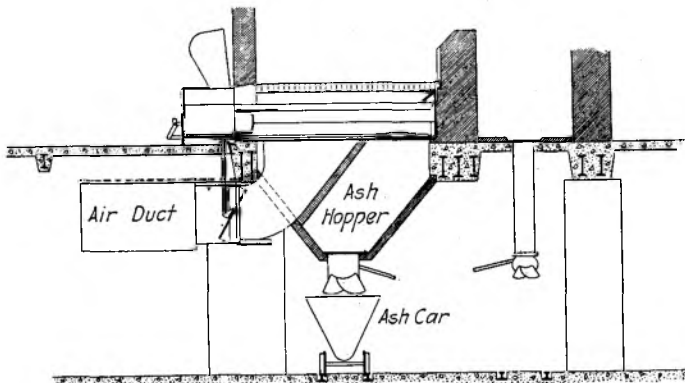

FIG. 10 HOPPER ASHPIT FOR SIDE-FEED STOKER

being taken care of outside the ashpit. The method of conveyance from the ashpit will have considerable bearing on the ashpit capacity necessary. But 24 hours' capacity should usually be provided in case of breakdown of conveyors, etc. Consequently some of the attributes of different methods of conveyance which bear on ashpit capacity should be mentioned here. The largest ashpit capacity will be requisite with conveying systems which are operated intermittently. These will include instances where ashpits are dumped into standard or industrial railroad cars, or into conveyors which might be choked by the direct dumping of an accumulation containing large clinkers and therefore need hand feeding or at least manual attention. Where a continuous-conveyor system is used the ashpit may be much smaller, and sometimes the ashpit becomes simply a funnel or chute to guide the ashes into the conveyor, as in Figs. 22 and 31.

27 Since the required capacity depends upon the amount of ash that accumulates between emptyings, it is controlled by the rate of firing and the percentage of ash in the coal. Multiplying the weight of coal burned between dumpings by the percentage of ash and allowing 40 lb. per cu. ft. gives the storage space required. Allowance must be made for unburned coal coming in with the ash, for neglect to empty regularly, for possible increase in the load and consequently in the rate of combustion, and for possible change to dirtier coal. The careful engineer will make the capacity of his ashpits perhaps 50 per cent greater than the calculations show, or even more. Also, sufficient space should be left above the top of the ashes in order to prevent burning and breakage of stoker mechanism.

#### HOPPER-ASHPIT DESIGN

28 The sides should slope at not less than 45 deg. in any case, and a minimum of 50 deg. with the horizontal is preferable. If one side is vertical the opposite side may have the minimum slope; but where two opposite sides slope, neither should slope less than about 55 deg. If the slope is too small, arching of the ash is likely to occur, and this will increase operating costs owing to the frequent necessity of encouraging the flow by breaking away the ash with bars poked up through the discharge doors. Where the width of the hopper would necessitate too great height to get these required slopes, the ashpit may easily be divided so as to have a number of discharge openings. An excellent example of reversed slope which results in absolutely reliable dumping is illustrated in Fig. 19.

29 If a very small slope is used so as to get large capacity such as in Fig. 8, access doors should be provided at the top of the slope so that the ashes may be pushed to the dump doors with a minimum of labor, and ample space should be left so that long ash tools can be wielded with ease.

30 Large discharge openings should be used, though their size depends to some extent upon the method of firing. When small anthracite is burned with sufficient steam in the combustion air, no clinkers are formed and the ash is in small pieces and easily dumped. Modern intensive firing of bituminous coal tends to cause the formation of large clinkers, and the openings should be large

enough to pass these without having to break them into smaller pieces to allow dumping. In earlier installations, door openings about 18 in. square and even less were common, while modern practice required 30 to 36 in. as a minimum, with many instances of clear openings 5 ft. square.

31 In some instances the discharge door is in one of the sides of the hopper as in Fig. 7, and the attendant hoes out the ashes either into cars or conveyor. Whenever it can be adopted, however, the bottom discharge is undoubtedly the least costly in labor and well repays the added expense of the greater height of basement needed.

32 The height of the bottom of the hopper above the basement floor depends upon the system of conveyance adopted. It is greatest where standard railroad cars are used, about 8 or 9 ft. to clear the cars and about 17 to 18 ft. if a locomotive must pass under. With industrial cars 5 or 6 ft. is sufficient, though a clear headroom of 6 ft. 6 in. to 7 ft. is preferable. With some conveyors it may be much less, but in any case there should always be sufficient vertical space to allow a bar to be pushed up into the hopper to clear away any obstruction. In designing new plants ample headroom should always be provided.

33 Where storage takes place in the ashpit, water spray pipes should be provided for quenching the ashes. These pipes should be near the top and sheltered from the incoming ash. Or a substantial spray ring such as illustrated in Fig. 14 may be used. Many prefer to make the hopper sufficiently large for the ashes to remain long enough to cool naturally. By allowing some ash to remain when dumping, for the new hot ash to fall on, the doors and lining are protected and the ash gradually cools without the use of water. If too much water is used it will leak from the dump doors and flow about the basement; and as it contains much fine ash in suspension, it will clog sewers and necessitate cleaning them frequently.

#### HOPPER-ASHPIT CONSTRUCTION

34 The hopper is usually worked into and suspended from the general structure at the firing-floor level, to avoid any supporting columns which would block up the basement thoroughfares.

35 Hopper shells have been made of sheet steel lined with

firebrick, but this construction is undesirable owing to rapid corrosion from sulphur in the ashes. Shells of reinforced concrete about 6 in. thick are common and satisfactory. The most modern construction, and probably the best method so far devised, is to use a structural-steel skeleton and make the shell of substantial cast-iron flanged plates bolted together. Corrosion is not troublesome because cast iron suffers much less than steel from this cause. This construction facilitates connection with the upper structure and with the dumping-door frames.

36 Owing to the heat of the ashes and the possibility of the combustion of unburned coal, the hopper shells should always be

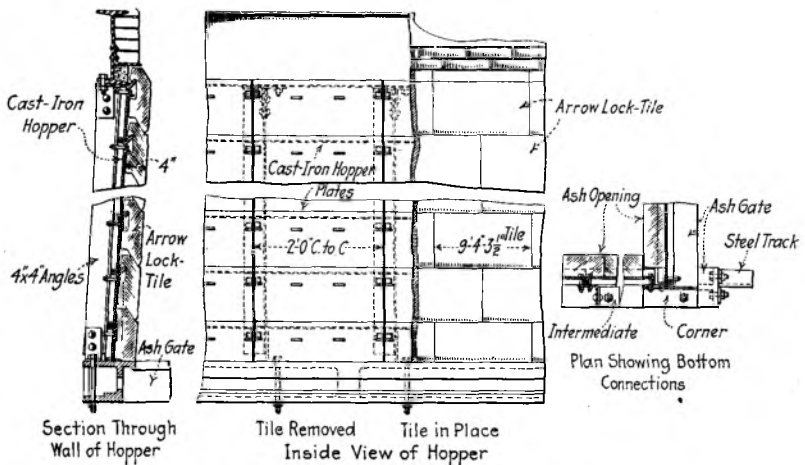

FIG. 11 BAKER-DUNBAR-ALLEN ASHPIT

lined with firebrick, which may be of second quality. With proper quenching of the hot ashes with water sprays a lining of well-burned hard paving brick is very satisfactory.

37 The method of construction of the Baker-Dunbar-Allen hopper ashpit is illustrated in Fig. 11. A suspended skeleton of structural steel carries the hopper shell of heavy cast-iron flanged plates. The lining is of special firebrick blocks which will not spall under the temperature changes which occur. As is seen in the left-hand view, these blocks are hung from the shell and interlocked in a manner that prevents displacement but allows of easy renewal, and no mortar joints are used.

## HOPPER-ASHPIT CLOSURES

38 Hopper ashpits will usually be provided with doors to retain the ash and prevent the passage of air, and to allow of the ash being dumped or hoed out at intervals as desired. With hand firing and natural draft the doors need not be airtight so far as draft is concerned; but with chain grates and with closed-ashpit forced draft the doors should be tight to avoid loss of air pressure and waste of blower power. Inleakage of air may reduce boiler efficiency in some cases by excess air passing the fire through the stoker ash dump; and when forced-draft

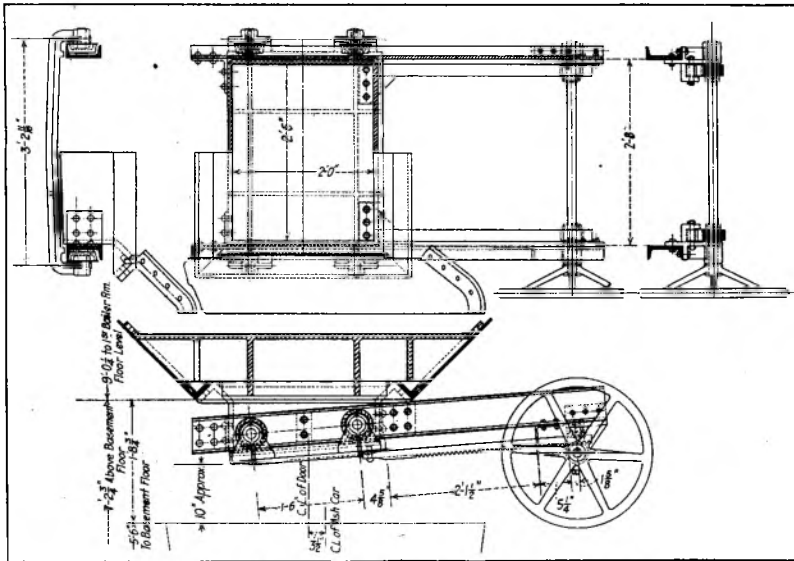

FIG. 12 ASSEMBLY OF ASHPIT DOOR AND FRAME

stokers are heavily loaded, gas may escape through the dumping doors. Where much combustible gets into the ashpit, either through carelessness or imperfections in stoker design, leakage of air through ill-fitting dump doors often causes sufficiently rapid combustion in the ashpit to result in damage to grates, hopper structure, or dumping doors. Airtight ash doors are therefore highly desirable in almost all cases.

39 There are several ways in which the dump openings may be sealed. The doors and faces may be machined, or the frame

may be provided with a groove packed with asbestos rope, while the door has a rib or tongue which is squeezed into the asbestos-packing by a cross-bar and screw spanning the door. The latter method has been used with satisfaction in vertical doors like that of Fig. 7. The door and frame may sometimes be left unfinished with sufficiently well-fitting smooth-faced castings that will prevent much ingress of air. The doors should usually be lined with firebrick to prevent warping due to hot ashes lying on them soon after dumping.

40 An example of ash door is illustrated in Fig. 12. These doors are of substantial construction, and are carried on rollers

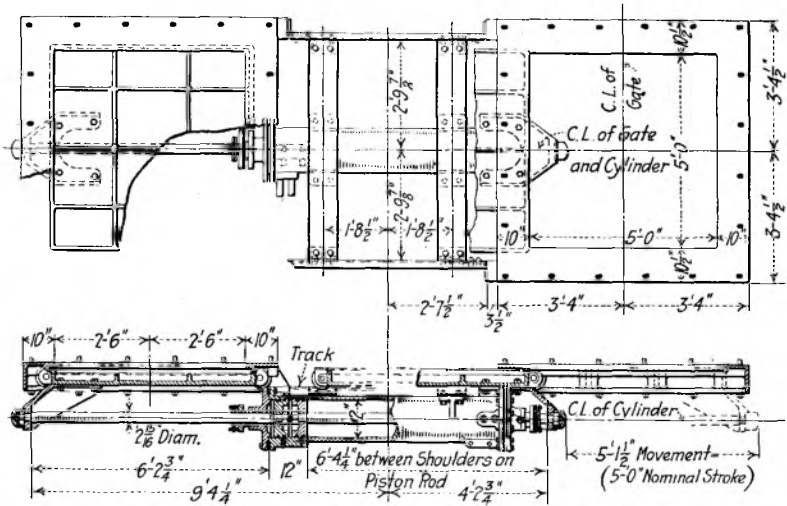

FIG. 13 BAKER-DUNBAR-ALLEN POWER-OPERATED ASH DOORS

running on steel members. They are operated by hand with rack and pinion. They were designed and installed in the station using the system illustrated in Figs. 17 and 18 in 1916, and continue to operate with entire satisfaction. Smaller doors are operated by hand, but when the openings approach 3 ft., power operation is advisable for speed. The larger hand-operated doors are worked by gearing such as rack and pinion, while power operation may be hydraulic, compressed air, or electric.

41 Fig. 13 illustrates two Baker-Dunbar-Allen dumping doors arranged for compressed-air or hydraulic operation. The cylinder is worked in between the openings and contains two pistons, one connected to each door. The doors are lined with firebrick.

42 The Diescher dumping door is shown in Fig. 14. This door is provided with rollers which run on a curved track. Owing to the curvature of the door in conjunction with the flanges which carry the rollers, it retains water to form a seal, and this water renders lining unnecessary. Of course, when ashes are dumped the seal is lost; but as more water enters through the sprinkling pipe the seal is quickly remade. The door can be run off the track and another door run on if replacement is ever necessary by simply removing

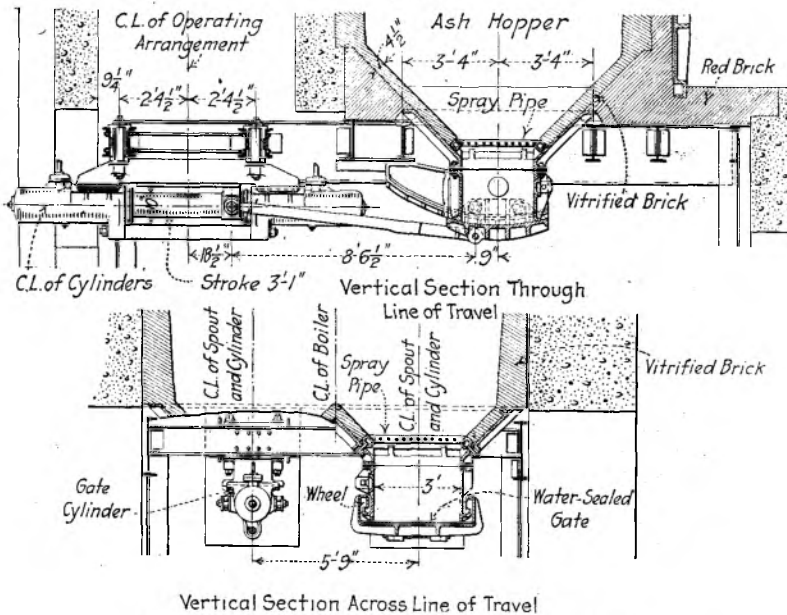

FIG. 14 DIESCHER POWER-OPERATED ASH DOORS

the pin of the driving connection. There is ample power and strength to shear easily through any clinkers which may get caught during closing.

43 Fig. 15 is a view of the basement of the boiler room of the Kelly-Springfield Tire Company, where the hopper ashpits consist of heavy cast-iron flanged plates bolted together and to the frames of the Diescher doors. The operating valves are above the concrete pads at the right. These pads are provided to protect the operating valves from ash cars being maneuvered near them. In this instance the basement floor has been temporarily raised owing to the use

of small ash cars which dump the ashes for filling about the premises. Whenever it becomes necessary, the basement floor level will be dropped to accommodate standard-gage railroad cars.

44 Piston-operated doors may use steam or compressed air, or may be operated from the feed line at some point where it will not interfere with correct recording of water fed to boilers, or from the city water supply; or a pump may be installed especially for this purpose to supply water at about 100 lb. pressure. If boiler feedwater is used, care must be taken to use hot-water packing in cylinders and valves. Instead of piston drive they may be operated by electric motor through gearing. The rugged con-



FIG. 15 ASH BASEMENT OF KELLY-SPRINGFIELD TIRE CO.

struction of these power-operated doors to meet their severe service, together with their size and elaboration, shows very striking differences from comparatively recent practice in large power stations, and clearly indicates the careful thought which has been given to this subject in recent years.

45 Instead of using doors, closure may be effected by water seal. This method may be described as a U-tube with one leg forming the hopper ashpit while the other is open to the atmosphere and possibly to the entrance of a clamshell bucket. Water in the bend of the U-tube forms a seal and serves to quench the ashes.

46 An excellent example of this method is illustrated in

Fig. 16, which is a cross-section of the boiler room of the Springdale Station of the West Penn Power Company. The operation of this system is very simple indeed. More than sufficient water for the seal is provided by the waste cooling water from the clinker grinders. The overflow is from one ashpit to the next, until it is finally discharged from the last ashpit.

47 This system of ashpit requires considerable depth of basement: not less than about 30 ft. from firing floor to basement floor. At Springdale it is 35 ft., and as deep excavation for foundations is necessary, extensions will probably have much deeper ashpits. These deep ashpits provide excellent storage. Actual test shows

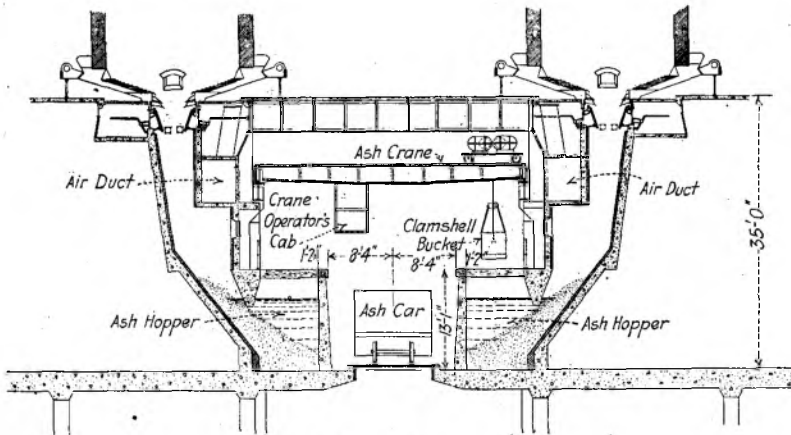

FIG. 16 WATER-SEALED ASHPIT

the present ashpits to have a capacity of three days' operation at 200 per cent continuous rating of the boilers.

48 Removal of ashes from the ashpits is by traveling crane and clamshell bucket, and is one of the most comfortable and easy jobs around the plant. One crane operator handles the ash output of the station in two hours per day.

49 A further advantage of this method is that no combustible or corrosive gas escapes into the basement. When boilers are being pushed with heavy loads, gas often escapes from hopper dump doors. Apart from discomfort and danger to those in the basement, considerable corrosion of ironwork often occurs. Such troubles are entirely obviated with the water-seal ashpit.

## MECHANICAL CONVEYANCE

50 The method of conveying ash by emptying ashpits into small dumping cars has a great deal to recommend it. The cars are inexpensive, so that one or two idle spare cars are not objectionable, and the cars can then be repaired without interrupting ash conveyance in the slightest degree. The cars can be moved by men, animals, tractors, or locomotives; and they can be run about the floor or on tracks, all according to the amount of ash to be moved and other conditions. They can be run about the premises and dumped to fill depressions, or lifted on elevators to be dumped into an elevated ash bunker, or be dumped into the bucket of a whip hoist. In installations of this kind there is always much dust, unless water is supplied in the hopper to quench the ash before discharging into the cars.

51 In a subject of this nature wherein classification and direct comparison between plants and methods are virtually impossible, instances where advantageous changes have been made have very great value. The authors feel particularly favored in being able to draw attention to one or two cases of this kind.

52 In the Ashley Street Station of the Union Electric Light and Power Company, St. Louis, Mo., a system of industrial railway and ash cars was installed in 1905. The basement floor of this plant is 30 ft. below the flood stage of the Mississippi River, and this necessitated a watertight basement with consequent elevation of ashes.

53 The boilers are equipped with chain-grate stokers discharging ash into hoppers having a capacity of 24 hours. These hoppers are of steel plate lined with vitrified brick laid in cement, and each has two large horizontal dumping doors which are illustrated in Fig. 12.

54 The railway is 30 in. gage and the dumping cars have a capacity of three tons each. The cars were drawn by mules, and two men were required to load the cars and drive the mules. The cars were run on to either of two Otis elevators having a vertical travel of 120 ft., and two other men were required to run the full cars on to the elevator and remove the empties. Two more men at the top ran the cars off the elevator and dumped them into the ash bunkers. In all, six men were required for each of the two day shifts and four men during the midnight shift, making a total of 16 men

to handle the ash. The large number of men required to operate the system was mainly due to the fact that the men were not allowed to travel on the elevators, which were inspected for freight only. The elevated ash bunker had a capacity of eight railroad cars, which was about two days' production. The total storage capacity was therefore sufficient for three days' production of ashes,

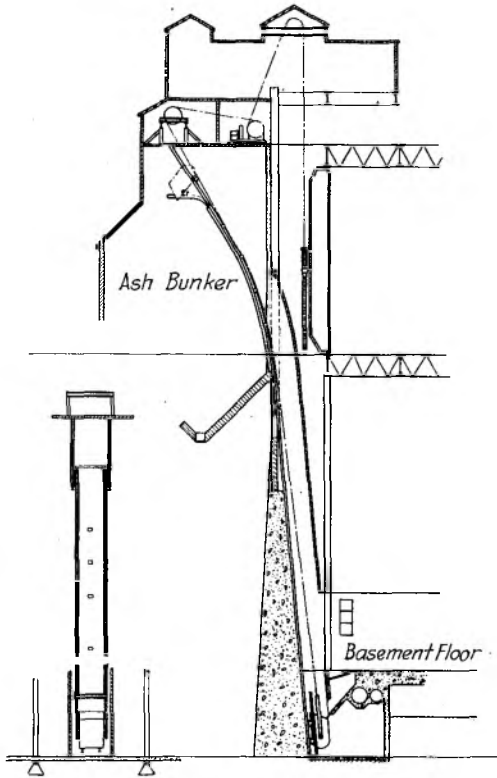

FIG. 17 SKIP HOIST

one day in the hopper ashpits and two days in the elevated ash bunker. To reduce the operation and maintenance costs, the use of the elevators and of mules was discontinued in 1916. The elevators were replaced by a bucket worked by a skip hoist and a storage-battery locomotive used to haul the ash cars.

55 This was one of the first installations of a skip hoist to handle ashes. The mechanism of the hoist was supplied by the

Otis Elevator Company, and the general arrangement is illustrated in Fig. 17. The same industrial railway was used with some small rearrangement of the track to bring the cars to the hoist. An excavation was made in the basement floor to accommodate the bucket of the hoist and the dumping hopper, and this required careful thought and work to avoid any disturbance of the circulating-water ducts.

56 The bucket is carried on four single-flanged wheels which run on two double-rail tracks of 5 ft. 3 in. and 6 ft.  $1\frac{1}{4}$  in. gage, respectively. There is a pair of wheels at the bottom of the bucket and another pair at the top. The lower pair run on the broader-gage track and the upper pair on the narrower gage. At the top end

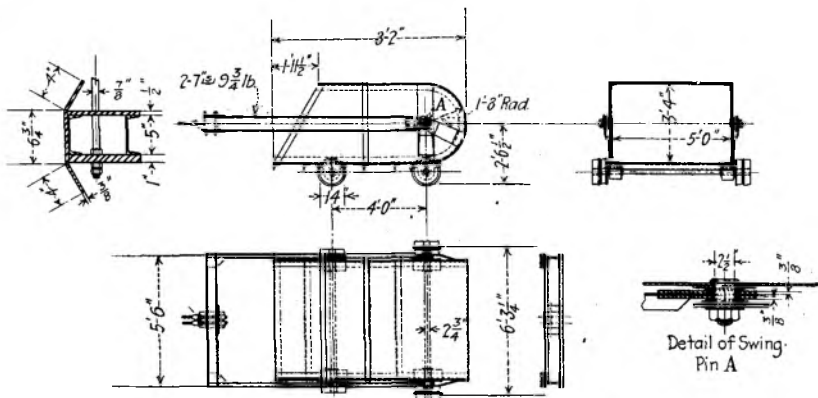

FIG. 18 DETAILS OF SKIP-HOIST BUCKET

of the run the narrower-gage-track rails are bent over as shown, so that the upper part follows the bent track and ceases rising, while the lower part follows the straight, nearly vertical, track until it becomes the higher. Thus the bucket turns over and empties into the hopper. It is counterbalanced by a weight having half the travel of the bucket, by carrying the balance rope around a sheave attached to the weight, as may be seen in Fig. 17. The details of the bucket are presented in Fig. 18.

57 In changing over from the elevators to the skip hoist, it was necessary to build a new elevated ash bunker to work in with the alterations in the new general layout.

58 The operation of the skip hoist is mainly automatic.

When an ash car has been dumped into the bucket, a switch button is pressed. This starts the hoisting motor, which raises the bucket to the top of its travel where it turns over and discharges into the elevated bunker. A switch trip at this point reverses the motor and thus lowers the bucket to its starting point, where another switch trip stops the motor. One pressure of the button therefore results in hoisting and dumping the bucket and in returning it to the starting point ready for another load. A spring safety bumper is placed 6 in. below the regular bottom stopping point.

59 The operation of this new system is entirely satisfactory and it has given good service. It has reduced the labor cost of handling ash one-third and the cost of maintenance one-half.

60 Experience with the storage-battery locomotive shows that in the heat of the basement the electrolyte evaporates rather rapidly, resulting in some battery trouble. A gasoline locomotive is now used and gives entire satisfaction.

61 The corrosive vapors in ash basements which come from ill-fitting dump doors when forced-draft boilers are heavily driven, and from exposed partly quenched ashes, are very destructive of steelwork. In many cases it has been found necessary to coat structural steelwork with gunite, and in modern stations concrete instead of steel in basements is usual. The health and comfort of the workers therein should also be considered, if only from the standpoint of economy, because labor will be easier to get and will be more efficient.

62 In the original system installed at the New Bedford Gas and Electric Light Company's plant, the ashes collected in hopper ashpits were emptied into Koppel dump-body ash cars. These cars had a capacity of 36 cu. ft. each, and were propelled by man power along a cast-iron track set in the concrete floor. The cars were pushed out into the yard and dumped into a large pit. When this pit was filled, a locomotive crane dug out the ashes with a clam-shell bucket and deposited them in an elevated concrete bunker. This bunker was so arranged that trucks could drive under and receive the ashes through the dumping door. The ashes were given away to the city and otherwise, and no expense was involved in their disposal after they had been put in the elevated bunker.

63 The use of the manually operated ash cars has been recently discontinued. A dump body of 40 cu. ft. capacity was adapted to a storage-battery truck, and the operation of the elec-

tric truck immediately eliminated four or five ash laborers. The large pit with the locomotive crane and grab bucket was also discontinued. An automatically controlled skip hoist with the skip car normally in a small concrete pit just large enough to hold the car, was installed about 30 ft. outside the boiler room. The truckman pushes a button switch which starts the elevator motor, and this raises the car, dumps it into the ash bunker, and returns it to the concrete pit ready for another load. The hoist, car, and

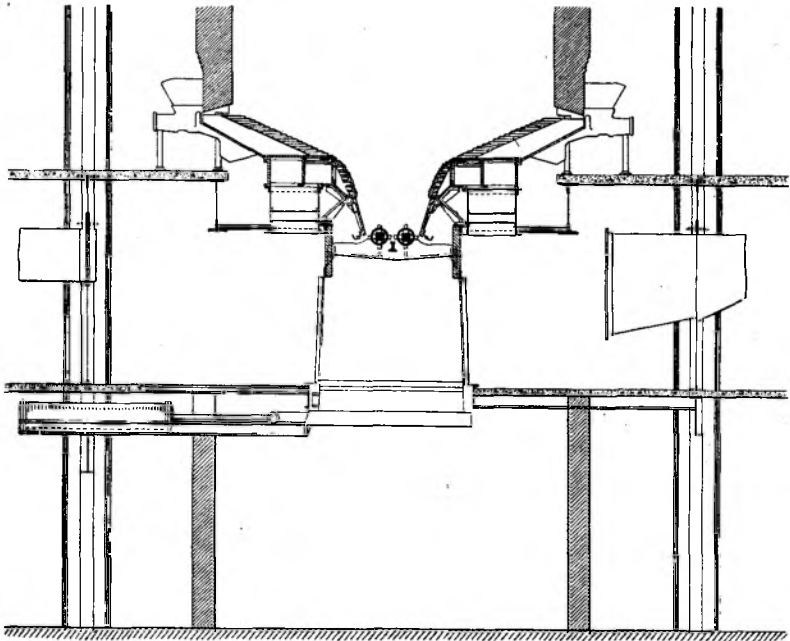

FIG. 19 HOPPER ASHPIT FOR DUMPING INTO STANDARD GONDOLA RAILROAD CARS

electric controls were furnished by the Geo. T. McLauthlin Company, of Boston, and have given entirely satisfactory service. Two men now handle the ashes from the station, which has a load of about 38,000 kw. at the present time. The cost of maintenance of the electric truck has been comparatively low.

64 Fig. 19 illustrates a hopper ashpit arranged for dumping directly into standard gondola railroad cars which form part of the equipment of the station. The hoppers are lined with brick, not shown, and have a capacity of about 2500 lb. of ashes. The stokers

are equipped with clinker grinders. The ash gates are of the sliding type and are operated by compressed-air cylinders. Water spray pipes are provided near the top of the hoppers for wetting down the ashes before dumping.

65 The present consumption of this station is 413,000 tons of coal per year. The ash content of the coal by analysis is 11 per cent, and the produced ash contains 13 per cent of combustible. The yearly ashes from the station amount to 52,800 tons.

66 The ash cars are handled by an electric locomotive and are dumped into an outside pit, from which they are recovered by a crane and grab bucket and loaded into the purchaser's trucks. The electric locomotive and the crane are also used for coal handling, and careful time study shows that 25 per cent of their time is devoted to ash handling. Ashes were dumped once during each shift, so that three shifts of ash handlers were necessary. These ashes were all sold and the proceeds very nearly paid the labor cost of handling them.

67 The estimated cost of the necessarily increased height of the building due to this method of ash handling is naturally subject to comparison with some other system and is therefore not of value for general comparison.

68 It is estimated that 45 lb. weight of compressed air is required per day per boiler to operate the hopper-ashpit dumping doors. From recent tests it is found that 1030 gal. of water is used in spraying one ton of ashes, and this amounts to about 4 per cent of the total general-service water used by the station.

69 Bucket conveyors such as the Peck carrier have been extensively used. With the chain and buckets forming a ring system, the conveyor is often used for coal in the daytime and ash at night. The coal is received from crushers if necessary at one end of the building and elevated to a point above the bunkers into which the buckets are discharged. The ashes are dumped into the buckets during their lower run under the ashpits, elevated, and dumped during the upper run into an ash bin which can be discharged into railroad cars or motor trucks.

70 Fig. 20 illustrates a Peck carrier installation by the Link-Belt Company in a downtown heating station where coal and ash have to be handled by motor truck. The building occupies the entire site, and no projections of any kind are possible. The basement floor is 12 ft. below the alley level, and as the alley is only

15 ft. wide it was necessary to build a recess where the trucks could drive in and dump coal, and then load up with ashes.

71 The conveyor is located centrally between the boilers and handles coal as well as ashes, and also the siftings from the chain-grate stokers. The run-of-mine coal is screened as it is dumped from the truck, the screenings going directly through the feeder to the conveyor, and the lumps passing through the crusher.

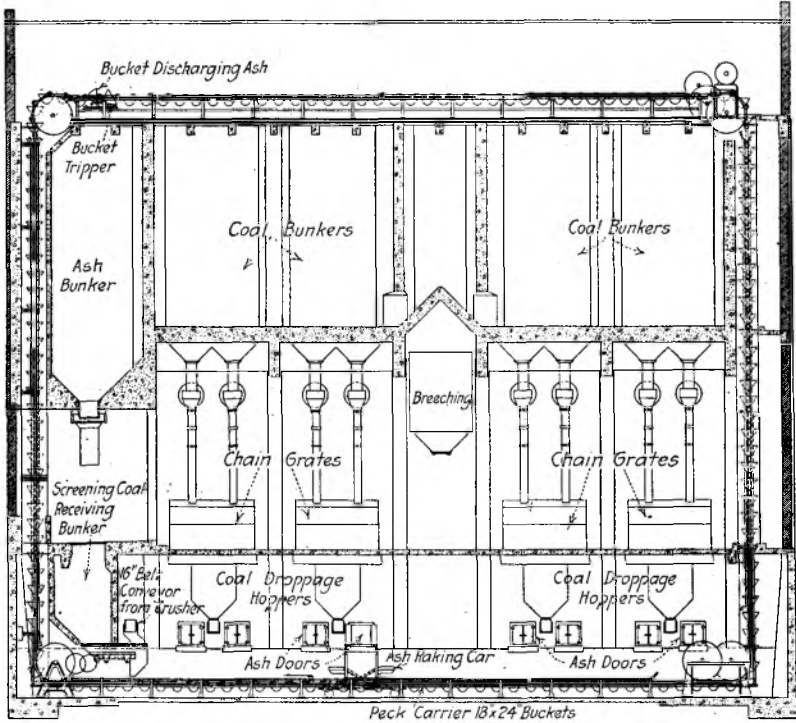

FIG. 20 PECK CARRIER RING SYSTEM

The vertical lift is 66 ft. and the horizontal centers are 85 ft. The overlapping buckets are 18 in. wide and 24 in. on centers. A 7.5-hp. motor drives the conveyor at a speed of 45 ft. per min. The buckets are discharged into the overhead bunkers by a regular tripper on the upper run.

72 The coal bunker is continuous along the boilers. The ash bunker, which has a capacity of 130 tons, is located in line with and immediately adjacent to the coal bunker and at the same elevation.

Consequently the buckets discharge coal into the coal bunker or ash into the ash bunker according to the position in which the tripper is placed. Also, the ash-bunker discharge is immediately above the recess into which the trucks are driven, just as the coal-receiving hopper is immediately below it. Therefore the trucks, which have automatic dump bodies, drive into the recess over the

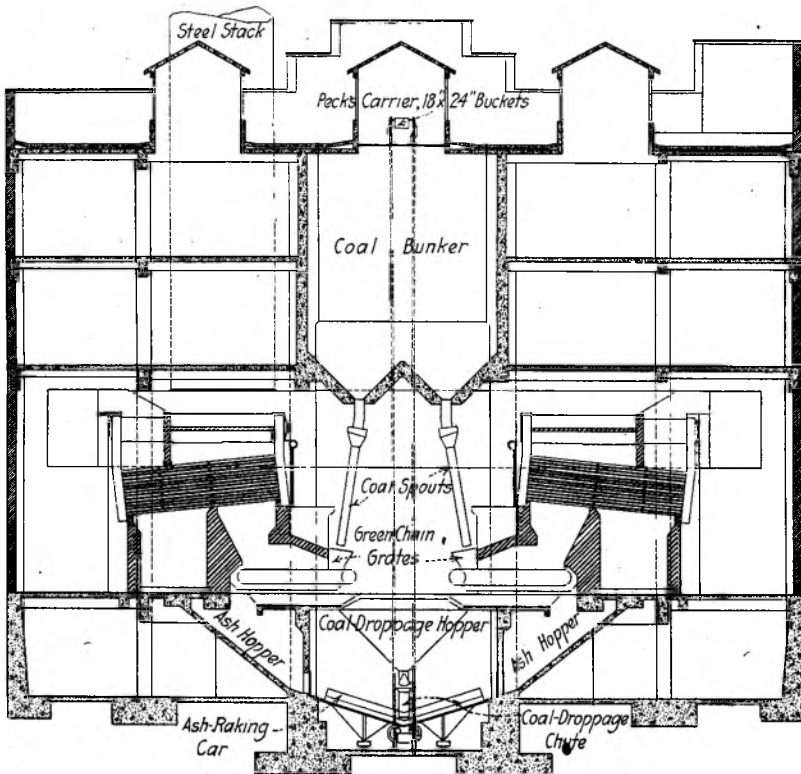

FIG. 21 CROSS-SECTION OF BOILER ROOM WITH PECK CARRIER

coal-receiving hopper, discharge their load, and receive ashes without changing their position. The ash gate is operated from the floor level. All coal and ash hauled to and from the plant must necessarily be carried in large trucks. Quick unloading and re-loading therefore materially increases the road time of the trucks; and this is a considerable item in the downtown district where traffic is more or less restricted.

73 A novel method is employed for the removal of the ashes from the ash hoppers to the conveyors. A double raking apron is contrived as a car mounted on tracks and straddling the conveyor. It is movable the entire length of the boiler house and can be brought in front of each ash door, forming a continuous chute from the hopper door to the conveyor. The operator stands on one side of the car and pulls the ashes down into the chute. After a flow of ashes has been created, water under pressure is used to keep up the flow, and the ashes are removed in a very short time. The cross-section of the plant shown in Fig. 21 illustrates this clearly. Considering the location and the surrounding restrictions, the general arrangement proved ideal for the purpose and has given good service.

74 A great deal of trouble can occur with conveyors of this type when allowed to reverse with a loaded chain. Although the manufacturers of the equipment provide a safety device, it was found necessary in this installation to devise a positive means of preventing reversal of motion. This has been accomplished by means of a band brake similar to those used on hoisting engines.

75 Owing to the abrasive nature of ash the maintenance cost of mechanical conveyors is high. The ashes grind away the connecting pins, and even with regular renewals the pins sometimes wear excessively and cause breakdowns. With a ring bucket system breakdowns are sometimes quite serious, as the ashes may have to remain in the basement for some days before the conveyor can be got to work again; and keeping the plant running under such conditions is very far from comfortable.

76 When handling coal and ashes in the same conveyor there is the difficulty of the fine coal and wet ashes packing in the buckets, so that there is a needless continuous load on the equipment with a corresponding reduction in carrying capacity. The water which leaches from the ashes is exceedingly corrosive and helps to carry the fine abrasive ash into the wearing parts.

77 The life of these conveyors is considered to be about seven or eight years, and extensive repairs must be made every two or three years. The excessive cost of maintenance of ash conveyors of this kind has led to their replacement in some installations with electrically operated cars carrying the ashes to outside pits from which they are loaded into railroad cars with a bridge crane, and the cost of handling has been reduced by 50 per cent.

78 Hopper ashpits with large doors should not be dumped directly on to chain or bucket conveyors. To avoid choking or swamping them, an apron or auxiliary hopper may be used with advantage. With ashpits such as that shown in Figs. 4 and 21, there is no such danger as the ashes are delivered more gradually. With direct dumping, large clinkers are liable to jam and cause breakdown, and opportunity should be given for breaking them.

79 The Fisk Street and Quarry Street stations of the Commonwealth Edison Company of Chicago are each equipped with bucket conveyors which handle both coal and ashes. There is an additional pair of ash conveyors at Quarry Street which carry the ashes to the train shed.

80 The apron conveyor is a modification of the bucket conveyor and consists of flat overlapping sheets with side flanges attached to a chain and forming a continuous steel-belt conveyor. Four such conveyors were intended for installation at Fisk Street, Chicago. Three were installed and put in service, but the cost of operation and maintenance proved so high that the fourth was never installed. The parts of the fourth were used to repair the other three. An electrically operated ash car is now used in place of the fourth, and the other three apron conveyors are being replaced with similar ash cars. The cars are dumped into a pit outside the building. A bridge crane takes the ashes from the pit with a grab bucket and loads them into railroad cars. The cost of maintenance as compared with the apron conveyors is almost negligible. The outside pit and crane were originally installed for and used with the apron conveyor.

81 At Northwest and Calumet stations, Chicago, the ash is dumped from hopper ashpits directly into railroad cars. The only maintenance required is upkeep of ashpit linings and dumping doors. The cost of the ash-handling system at these stations cannot well be estimated because there is none. But the buildings must necessarily be higher to get head room under the ashpits, and the increased cost of the greater height is obviously chargeable to ash handling.

82 An example of a simple chain and cross-bar conveyor is illustrated in Figs. 4 and 5. The conveyor installed at one of the municipal plants of the Poplar Borough Council in England<sup>1</sup> and illustrated in Fig. 22, may be considered as a development of

<sup>1</sup> Described in *The Engineer* (London), August 5, 1921.

this idea in combination with the water seal of Fig. 16, though there is no ashpit storage. In fact, there is no ashpit, only sheet-steel unlined chutes ending in cast-iron nozzles which dip below the water level in the conveyor trough, thus providing the water seal.

83 The conveyor is in duplicate so that one can always be in use in the event of breakdown of the other. The conveyor trough, which is of cast-iron plates, is divided by other cast-iron plates along the center. Each channel houses two chains connected by cross-bars which drag the ashes along the bottom. The return of the chain is also below the surface of the water. The transverse centers of the chain are  $19\frac{1}{2}$  in. apart and the cross-bars

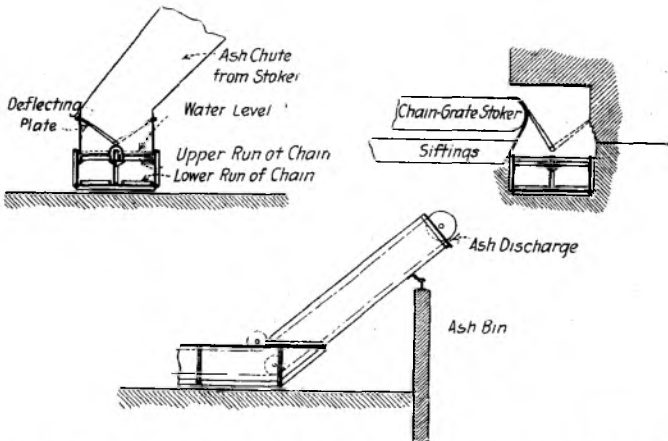

FIG. 22 WATER-SEAL CHAIN AND CROSS-BAR CONVEYOR AT POPLAR, ENGLAND

are  $25\frac{1}{2}$  in. pitch. Therefore large clinkers easily fall between the upper run of the chains and cross-bars to the bottom of the trough. The end of the trough is carried upward at an angle of 41 deg. to its discharge into the ash bin, from which the ash is recovered by grab bucket.

84 The views of this conveyor shown in Fig. 22 will serve to give a good idea of its arrangement. The upper left-hand view shows a general cross-section of the trough. The water level is maintained close to the top by ball valves on the water-supply line. The double cast-iron nozzle on the end of the ash chute dips below the water to form the seal, and is provided with a deflecting plate

which may be swung over so as to guide the ashes into either conveyor as desired.

85 The upper right-hand view is of particular interest in that no vertical space was available, not even for an ash chute. This chain-grate stoker was provided with a guard plate around the rear end, and the deflecting plate may either be against this guard plate and cause the ash to be discharged into the right-hand trough, or against the bridge wall so as to discharge into the left-hand trough.

86 The lower view shows the discharge end of the conveyor. The channels are continued above the water surface by an open-top double trough of sheet steel which carries the driving sprockets at its upper end. Idler sprockets carry the chain around the angle. The chain-tightening gear is at the other end of the trough.

87 The chain is made up of drop-forged links, alternate links having integral hubs which enter the other links and so provide large wearing surfaces. After six months' use no sign of wear or corrosion was apparent. It is of interest to note that corrosion is not expected because the water in the trough becomes alkaline rather than acid. The quantity of make-up water required is about 40 per cent of the weight of the ashes handled.

88 No ash crushers are necessary as the space between chains and cross-bars is sufficient to allow large clinkers to fall through the upper run of the chain into the water; and the hot clinkers break up on falling into the water. It is reported that the ashes as delivered from the conveyor are in a finely divided state, the average size of the pieces being about equal to that of a pea. They thus form an excellent aggregate for cinder concrete.

89 The length of this conveyor is about 140 ft. and it is designed for a chain speed of 20 ft. per min. One conveyor running at 9.5 ft. per min. and handling 3.25 tons of ashes per hour takes a little under 2 hp.

90 In some other installations only a single conveyor is used with auxiliary chutes for use in case of breakdown. They are constructed by the Underfeed Stoker Company, Limited, of London, England, who own the British patents for the system; and by the Combustion Engineering Corporation, who own the American rights.

91 In addition to the ashes from the main ashpit, the fly ash and soot from the boiler setting must also be cared for. Sometimes a chute to the main ashpit will meet the case, but care must be

taken to close the chute with a suitable valve or damper to prevent air passing into the boiler setting. Reference may be made to Figs. 9, 10, 21, 24, and 26 for methods of dealing with fly ash; and the chute for this purpose may be seen between the operating cylinders of the dump doors in Fig. 15. It is one of the outstanding advantages of the air conveyor that it can be piped so easily to handle soot hoppers in boiler and economizer settings, flues, chimney base, etc.

#### FLUID CONVEYORS

92 The salient advantage of fluid conveyors is that there is no mechanism to wear out, which is very important owing to the abrasive nature of ash. This does not mean that there will be no wear, but as the worn parts are stationary, an enormous amount of wear may take place before renewal is necessary, and such renewal is generally very easily effected.

93 As only two fluids are economically available, such conveyors may be classified into air conveyors and water conveyors. In either case, the fluid must have sufficient velocity to propel the ash; and since this velocity depends upon the density of the fluid, it is obvious that the velocity in air conveyors must be very much greater than in water conveyors. As the velocity is so high in air conveyors, the abrasive effect is also high and the wear heavy. Especially is this the case at elbows, and inexpensive wearing backs must be provided which can be easily renewed. It is to be expected that more power will be expended to move the ash at the high velocity necessary with the air conveyor, since the momentum given to the ash is so much lost energy.

#### AIR CONVEYORS

94 Air is passed through a pipe at a sufficiently high velocity to carry the ashes along with it. The air is admitted at one end and ash intakes are provided wherever required. There are two systems of generating the air current. In one, the pipe outlet is connected to an ash-storage tank in which a vacuum is caused by means of a steam-jet or mechanical exhauster. In the other, the air current is induced by a steam jet between the ash intakes and the outlet.

95 A typical layout of an air conveyor with vacuum storage

tank is illustrated in Fig. 23. A steam-jet exhauster is attached to the top of the tank and may discharge into the atmosphere or into the chimney or a silencer to reduce the noise. A mechanical exhauster may be used instead of the steam jet because only a little of the ash dust passes through it, and this may be reduced to a minimum by the judicious use of water sprays. It is probable that this system takes a little more power to operate, because the average density of the air in the conveyor pipe is low, and a greater weight of air is therefore required to convey the ash. But this may easily be so overshadowed by other advantages as to be quite negligible.

96 As the highest velocity which can be attained by particles

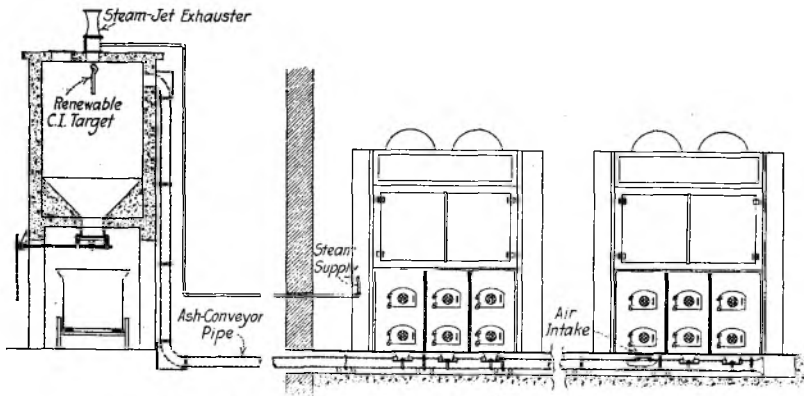

FIG. 23 AIR CONVEYOR WITH VACUUM STORAGE TANK

of ash is approximately that of the air, the wear seems likely to be less than where there are steam jets in the conveyor pipe. It is claimed that ordinary gray iron piping may be used, and a test is offered wherein a piece of conveyor pipe was replaced with light wrought-iron pipe which showed but little wear after a year's service carrying 5000 tons of ash.

97 It is obvious that the steam jet, which is located in the conveyor pipe of the other system of air conveyor, could not be replaced by any kind of mechanical blower because the passage of the ash through it would quickly destroy it. An ash tank is not required as part of the system. The conveyor pipe may discharge into the atmosphere and be arranged to fill up depressions in ad-

jacent ground. But unless the ash is sprinkled with water before it leaves the conveyor pipe, the resulting dust may be objectionable. The conveyor pipe may discharge directly into railroad cars, though this is usually inadvisable because of the difficulty of not having an assured supply of empty cars and of the ash car blocking the track while being filled and possibly interfering with the use of the track for coal cars. It is usual for the conveyor to discharge into an elevated ash tank supported on columns, so that carts, motor trucks, or railroad cars may be run underneath the tank and be filled quickly by opening the ash valve in the bottom. If a storage hopper is used, a vent must be provided for the escape of the air.

98 The ash particles may momentarily attain velocities approximating to that of the steam jet at a little distance from the muzzle of the nozzle and therefore local abrasion may be considerable. It is usual to locate the motor jet at an elbow, as it is then convenient to aim the jet in the new direction. When the conveyor pipe is very long, extra nozzles are installed in some cases. These extra nozzles are sometimes located in elbows and sometimes in a run of straight pipe. When the nozzles are arranged in straight pipe they are set at an angle to the axis of the pipe and are then not so efficient as they would be if coaxial. It is not possible to place nozzles coaxially because they would be in the path of the ash, which would quickly destroy them.

99 The ash openings may be arranged in any position desired, such as in the firing floor in front of hand-cleaned ashpits, near the bottom of hopper ashpits, connected to pipes to draw soot and fly ash from the later boiler passes, etc. They will serve several lines of boilers as easily as one, and such lines do not need to be parallel but may be at various angles and at different levels. An air inlet is provided at the beginning of the pipe, for it must be remembered that it is the velocity of a large body of air which carries the ash, and not the vacuum. The inlet openings that are not in use should always be kept tightly closed with the plugs provided.

100 The speed with which ash is carried away by air conveyors of either type is surprising to any one who has not seen them in operation. It is not possible to choke an intake by as many men as can work around it shoveling and hoeing ash into it as quickly as possible, without heaping over the opening. Hence economical ash handling by air conveyors is largely dependent upon the convenient location of the intakes and the facilities for the most

rapid feeding possible without choking the intakes with clinkers. They will usually carry anything that will pass through the intake opening.

101 As an instance of the speed at which ashes can be handled, a plant may be cited containing fifteen 500-hp. boilers equipped with Murphy stokers, where the average amount of ashes in each pit ranges from 1000 to 1300 lb. One man cleaned out eight ash-pits in 27 min. from the time steam was turned on until it was turned off.

102 They should not be directly connected to hopper ashpits, however; such ashpits should discharge into auxiliary hoppers or funnels with stout gratings to hold back clinkers of such size as should be broken up before reaching the conveyor intakes. With modern intensive firing much higher furnace temperatures are carried than formerly, and this results in the formation of clinkers of large size. Some stokers are provided with clinker crushers, and when this is not the case it is becoming increasingly necessary to add clinker crushers as part of the ash-handling equipment, so that the clinkers may be reduced to such size as the conveyors can handle without choking or breakdown.

103 The maximum capacity of a 6-in. conveyor is about four tons of ash per hour; that of the 8-in., six to nine tons; and of a 9-in. conveyor, ten to fifteen tons and even twenty tons in some cases. The capacity depends largely upon the size of the pieces. Ash should not be wet or quenched when fed to an air conveyor.

104 Ashes can be conveyed by air conveyors through a horizontal distance of about 500 ft. and through a rise of about 100 ft. It is often better to use several conveyors, either with a common ash bunker or a separate ash bunker for each, rather than a single conveyor with several branches. The capacity will be greater and also the efficiency, because there will be less leakage from idle intakes and through isolating dampers. The conveyor pipe may be run in any direction, up or down, and around any number of corners. In this respect it possesses a flexibility of installation which is not approached by any other system, and it can be adapted to circumstances which no other method can meet.

105 The cast iron used for pipes and elbows and other fittings is generally made of the hardest possible white iron, such as is not machinable and can only be ground, so that connections are commonly made by means of bolts slid into open lugs. The wear is

greatest at elbows where the ash direction is changed, and it is usual to provide "wearing backs" of easily replaceable blocks.

106 As the ash is projected from the pipe at high velocity, some kind of easily replaceable target is provided in or near the ash hopper. The ash strikes this target and falls without horizontal velocity, for if it were directed at the opposite side of the tank, it would soon cut a hole through it.

107 Air conveyors use a large quantity of steam while running; but as they remove the ash very rapidly, the cost of steam per ton of ash removed is quite small when they are properly operated. If the conveyance of ash is interrupted while the steam is blowing, the waste of steam will naturally be very great and the cost of steam per ton of ash will rise very rapidly. If the cost of steam per ton of ash with a reasonable method of operation is recorded, then if the ash is only fed half as fast, the cost per ton will be doubled, because the nozzle discharges the same quantity of steam in either case. As this is a matter of seconds, it may easily become of great importance. Suppose the ash handler turns on the steam and then walks some distance to get a hoe or shovel and then to the point where he is going to work on the ash. Then more time may be lost in preparing to work at another ashpit. When all the ash has been blown away, there is the walk back to the valve to shut off steam. The steam may also be blowing while some interesting conversation is taking place instead of hoeing ashes. All this will result in enormous waste of steam. Therefore methods of operating the steam valve from the vicinity of the ash intakes are very valuable in saving steam.

108 The Green Engineering Company uses an electrically controlled steam valve. A foot-operated switch is placed in a convenient position near each ash intake, and the switch is connected to a balanced steam valve which is operated by a solenoid. Steam is then blowing only while the attendant is actually at work at any particular intake.

109 The United Conveyor Corporation's main steam valve is operated by a triple valve. A small valve which is opened and closed by a quarter-turn is located near each intake. When all the ash has been hoed into the conveyor, the small valve is closed and steam consumption ceases. When the operator has swept up the floor into the intake, the small valve is opened momentarily to remove the sweepings.

110 Considerable expense ensues if steam nozzles are allowed to wear excessively before renewal. Not only is the steam consumption greatly augmented, but the increased energy of the larger steam jet results in higher air and ash velocities with greater wear of pipes, elbows, targets, etc. Such wear of steam nozzles is greatest with wet steam. These conveyors are only used intermittently and as the steam nozzles are often so located as to require a long line of supply pipe, they are usually supplied with wet steam.

111 Several methods have been developed to guard against the continued use of excessively worn nozzles. One is to provide a local reduction of wall thickness near or at the throat so that comparatively slight wear will cause the thin wall to break through. The resulting steam leakage is arranged to blow a whistle and so warn those interested that a new nozzle should be put in. Another method is to make the entire nozzle with thin walls, about  $\frac{1}{8}$  in. When much wear takes place the nozzle bursts and puts the conveyor out of commission, and warns the attendant at the same time. A new nozzle is inserted in a few minutes.

112 In some instances the steam-jet conveyor is objectionable because the steam used represents so much water lost, and which must be replaced by "make-up." In modern central power stations boilers are loaded to 300 or 400 per cent of their rating during peaks, and the greatest care is necessary to avoid impure water entering the boilers under these conditions. It is becoming increasingly general practice to distill all make-up water so as to prevent any scale-forming or foam-making salts from getting into the boilers. Condenser leakage is diligently looked for and eliminated. Therefore, owing to the care with which pure water must be conserved, it is obvious that any apparatus which removes water from the system, such as steam jets whose steam does not eventually reach the condenser, will usually be frowned upon by operating engineers.

113 Of course, the matter entirely depends upon what proportion the steam so used would bear to the regular amount of make-up used by the station. One ton of steam will move four to eight tons of ash. The steam consumption depends upon the length of the conveyor, the height through which the ash is lifted, the number of bends, and the care used to economize steam during operation. With a coal containing 12 per cent of ash, two tons of steam would be used per 100 tons of coal. Taking an average evaporation of

9 lb. of water per pound of coal, the conveyor would use two tons of steam out of each 900 tons generated or nearly 0.2 per cent. To allow for careless operation or negligent maintenance and other contingencies, it would perhaps be advisable to allow say 0.3 or 0.4 per cent in arranging for extra distillation for make-up. If the make-up for the station is 2 per cent, then the distilling capacity would have to be increased by 20 per cent. If the make-up is higher, the percentage of increase will be less. It will also be less with cleaner coal. Whether this is prohibitive or attractive will depend upon the rest of the circumstances.

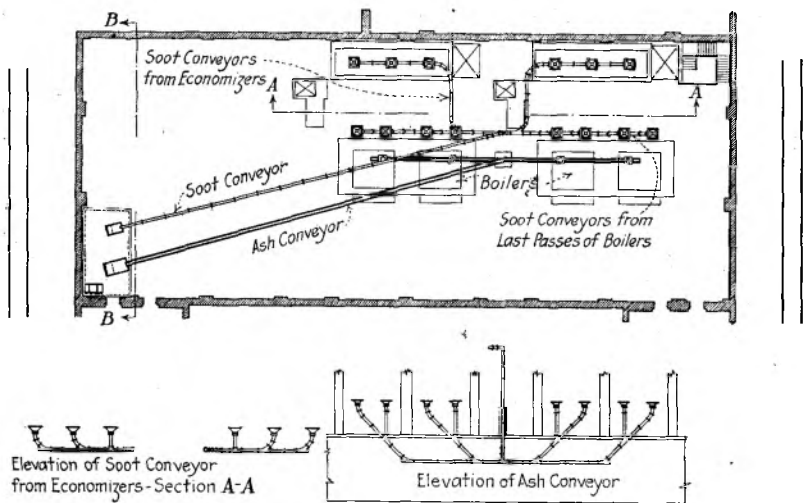

FIG. 24 AIR CONVEYOR AT MILWAUKEE SEWAGE-DISPOSAL POWER PLANT. PLAN

114 Air conveyors generally result in clean basements or firing floors because there is less spillage, as the tendency is always to draw the ash and dust into the conveyor. The first cost is usually lower than that of a mechanical system, especially when the only possible line of travel is tortuous. They take up very little space and can be installed in awkward positions, often such as are inaccessible to mechanical conveyors. The intakes and discharge can be arranged wherever desired, which is not always convenient with mechanical conveyors. They require very little attention; but this is not always a good feature unless periodical inspection is conscientious, because steam nozzles may wear and leaks due to abrasion

of pipes develop, and these may result in considerable waste of steam. The very convenience of the method may develop carelessness in allowing the steam to blow when ash is not being fed. It is safe to operate because there are no moving parts and this feature also makes for small expense of putting in renewals.

115 The air conveyors which are being installed by the Conveyor Corporation of America at the New Milwaukee sewage plant are illustrated in Figs. 24, 25 and 26. The plan in Fig. 24 shows the ash conveyor, which has a bore of 9 in., in conjunction with the four 734-hp. boilers equipped with Westinghouse under-feed stokers. The hopper ashpits are dumped into auxiliary hoppers formed about the conveyor intakes, as will be seen in Fig. 25. This permits of rapid feeding of the conveyor without

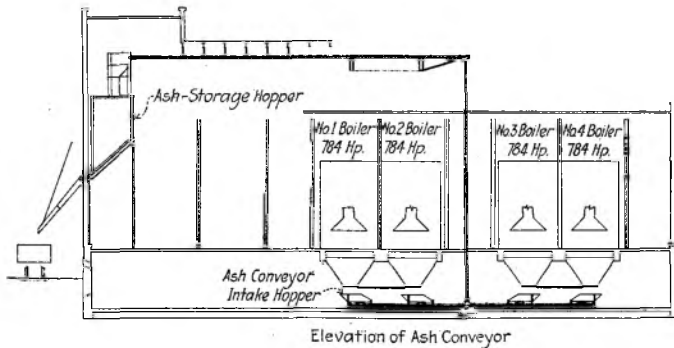

FIG. 25 AIR CONVEYOR AT MILWAUKEE SEWAGE-DISPOSAL PLANT. ELEVATION

smothering it. The elevation of the ash conveyor is shown in the lower right-hand view of Fig. 24. It is to convey a minimum of 12 tons per hour, with a steam consumption not exceeding 325 lb. of steam per ton of ashes.

116 The ashes are discharged into a target box above the storage bunker inside the boiler house. The storage bunker has a single slope bottom and is emptied through a movable chute into railroad cars as clearly shown in Figs. 24 and 25.

117 The conveyor for soot and fly ash is independent of the ash conveyor and has a bore of 6 in. This arrangement usually increases both the capacity and the efficiency over that obtained with combination conveyors. The arrangement of the soot conveyor is easily understood from Figs. 24 and 26. It is connected to the

later boiler passes and to the economizer, and discharges into a separate target box set upon the top of the ash bunker. As is seen in the left-hand view of Fig. 26, the conveyor pipes are connected directly to the boiler and economizer settings without the intervention of hoppers, and are provided with shut-off gates. Auxiliary hoppers are not necessary in conveyors for fly ash as there are no clinkers, and the conveyor can deal with this fine ash as fast as it can flow into the intakes.

118 The installation at the Lakeside plant of the Milwaukee Electric Railway and Light Company is of considerable interest

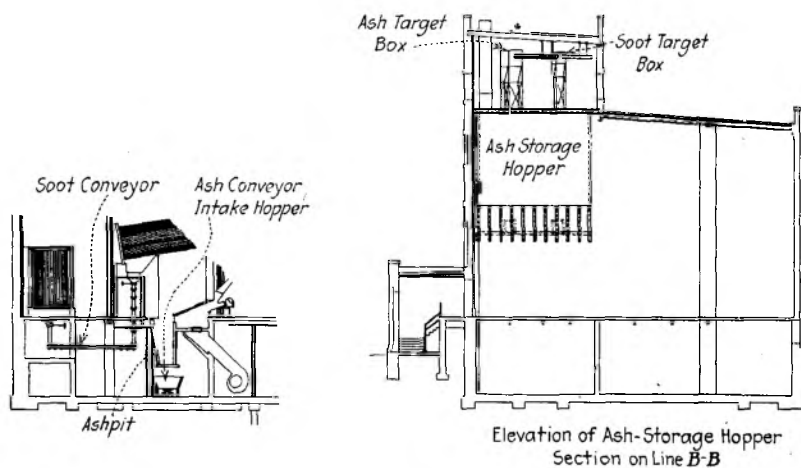

FIG. 26 AIR CONVEYOR AT MILWAUKEE SEWAGE-DISPOSAL POWER PLANT.  
CROSS-SECTION

because the boilers are fired with pulverized coal. There are eight boilers of 1333 hp. each — 1306 hp. in the boiler proper and 27 hp. in the form of a water screen at the bottom of the combustion chamber. This water screen extends over the entire combustion-chamber floor and might be called a tubular grid. This description is desirable because it appears that the water screen entirely prevents the formation of clinker or slag which was so troublesome in some of the earlier powdered-coal installations. Instead, the ash from the combustion chamber is a fine powder which is very easily handled by an air conveyor.

119 The air conveyors were installed by the Vacuum Ash and

Soot Conveyor Company and have operated in an entirely satisfactory manner from the start. They have been in operation nearly two years and practically no maintenance work has been required during that time. Only one nozzle has been replaced.

120 To recover some of the fine ash which would otherwise be discharged from the chimney top, a smoke washer is installed in the main flue about twenty feet before it enters the base of the stack. It consists of two 4-in. pipes placed parallel to each other in the top of the flue. These pipes are drilled and tapped to receive nozzles of  $\frac{1}{4}$ -in. pipe 1 in. long which are placed at 3-in. centers along each pipe, and the nozzles of one pipe are staggered relatively to those of the other. The pipes are supplied with about 350 gal. of water per min. at a pressure of about 6 lb. per sq. in. The jets from the nozzles form a water curtain through which the gases must pass before entering the chimney. Actual tests show that 50 per cent of the ash suspended in the flue gases is removed by this apparatus.

121 The water from the smoke washer falls into a trough formed in the bottom of the flue, and then runs off into a concrete settling basin carrying the ash it has collected. This basin is made of generous capacity to insure thorough settlement of the fine ash, and is 45 ft. long, 16 ft. wide, and 25 ft. deep. This roomy basin allows the inflowing water to become quiet so that the ash subsides; and it is then removed by a clamshell bucket operated by a locomotive crane. The water passes from the settling basin through overflow weirs into the circulating discharge tunnel from the condenser.

122 This smoke washer was installed after the building had been erected, and consequently cost a great deal more than if it had been designed and constructed in conjunction with the rest of the buildings and equipment. There has been practically no maintenance cost since it was started in operation.

123 The eight boilers are arranged in two rows of four each, facing each other across the firing aisle. There are two conveyors, the main line of each being in the floor of the ash alley in front of the furnace ashpits. Each main line takes care of four boilers. Branch lines lead to the ash chambers at the rear of the boilers and also to the ashpits under the economizers.

124 All the conveyor lines are of 8-in. cast-iron pipe. The running length of the two main lines is approximately 200 ft. with

a vertical rise of 65 ft. The lines from the ash chambers and the economizer ash hoppers are approximately 190 ft. long and have a vertical rise of 50 ft.

125 The conveyors discharge into ash bunkers, there being one bunker for each side of the boiler room. The ash from one bunker is discharged into cars, while the other is emptied down a closed chute into the ash settling basin of the smoke washer as

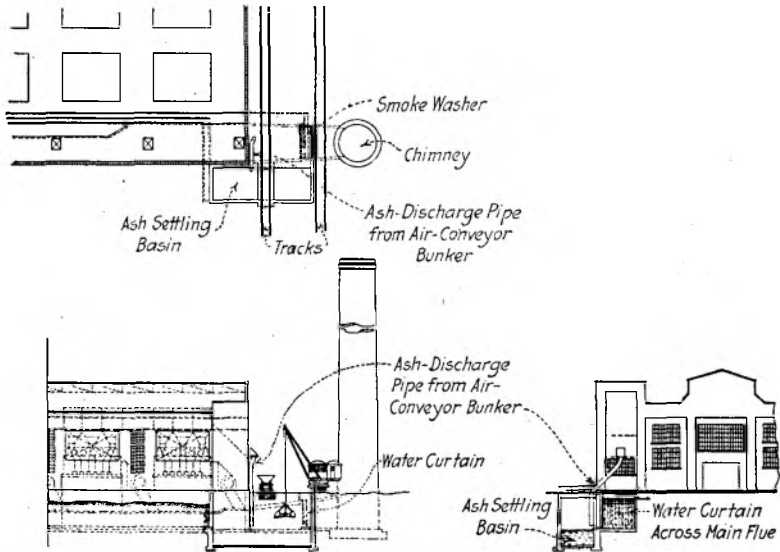

FIG. 27 AIR CONVEYOR AND SMOKE WASHER FOR PULVERIZED-COAL FIRING AT LAKESIDE STATION, MILWAUKEE

shown in Fig. 27. As already mentioned, the ash from the settling basin is removed by grab bucket and put in cars to be hauled away.

#### ASH BUNKERS

126 Considerable choice of materials and design of ash bins and supports is available. A large number, perhaps most, are made of reinforced concrete. In some cases they are inside the boiler room and worked into the general design of coal bunkers, etc., such as illustrated in Fig. 20. They are occasionally built so as to span an alley, being supported by the buildings on each side.

127 The height of the discharge gate will naturally depend

upon what must pass under it and is greatest where standard railroad locomotives must be accommodated. Frequently, the discharge is at the side, the whole of the bottom sloping toward the door, which is then generally provided with a hinged chute, which can be extended so as to deliver the ash into trucks or railroad cars.

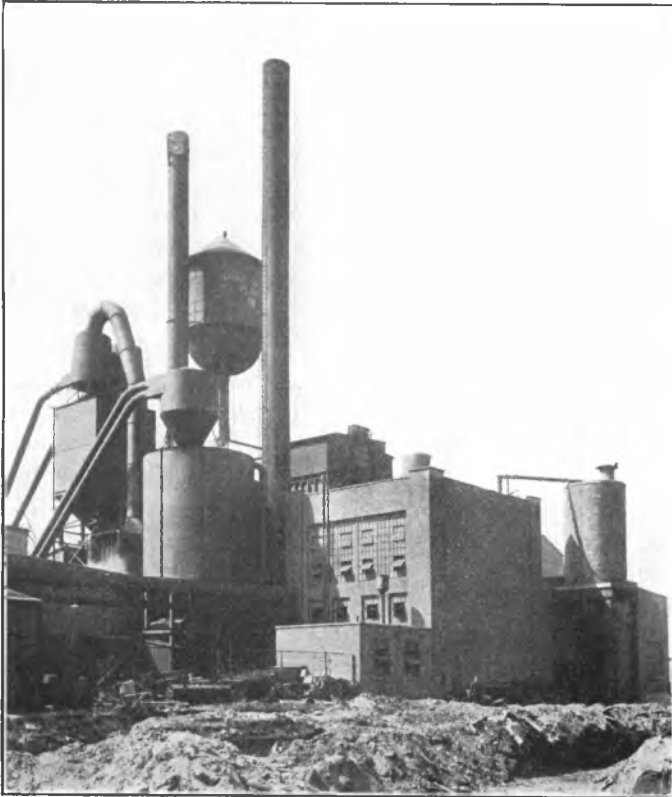

FIG. 28 HOLLOW-TILE ASH BUNKER

128 Ash bunkers have also been built of brick, but unless very thick walls are used, they should either be buckstayed or have reinforcing bands laid up every five or six courses. The bricks should be hard and well burned, and laid in cement. The inner face of the walls should be of paving brick.

129 Fig. 28 illustrates one of the hollow-tile ash tanks in-

stalled for the Fisher Body Corporation by the United Conveyor Corporation. These tanks have several inherent advantages in that they are fireproof, prevent freezing of wet ash, are acidproof, provide space for steel reinforcing rings within the wall, and have a smooth interior surface. The tiles are laid up in cement and are provided with key grooves on their joint faces.

130 The Green Engineering Company install tanks which are made up of a cast-iron skeleton filled in with cast-iron plates, the



FIG. 29 CAST-IRON-PLATE ASH BUNKER

whole carried on a structural-steel framework as illustrated in Fig. 29. Cast iron, being much less subject to corrosion than steel, makes a durable tank for ash storage. The plates are easily removed and renewed. A substantial dumping door operated by a hand chain through gearing is provided. Poking holes are arranged around the dumping door so that bars may be introduced to break down any arching or choking of the ash.

131 Care should be taken in making repairs to storage hoppers to insure men working in fresh air, owing to the possibility

of their being "gassed" with carbon monoxide from combustible in the ash. This can occur in any case where closed or nearly closed storage hoppers are used. It is easily avoided with reasonable care.

#### WATER CONVEYORS

132 Systems of water conveyance as used on shipboard have already been described and were illustrated in Figs. 1 and 2. They consist of closed conduits carrying water and ash under pressure.

133 In land practice the conduit is largely or wholly open. Such open ducts are fairly common in mining and other plants, generally in hilly places where a brook may be diverted so as to flow along a flume in the boiler-room basement. Great care should be taken to be sure of a plentiful supply of water at all times. In one instance a flume was carried under the boiler room at one side of a narrow tunnel. The men stood back in the tunnel and hoed the ashes from a hopper ashpit into the flume. In comparatively dry weather and with red-hot ashes there was not sufficient water to quench properly and carry away the ashes. The heat, flame, and steam in the tunnel at such times were practically unbearable; and the labor cost of moving the ashes by dragging them along the flume by hand was very high.

134 With a plentiful supply of water, however, this method has much to recommend it. There is no dust or heat and the ashes are carried away very quickly. Owing to the low velocity of the vehicle as compared with air, the wear is very small and usually is not troublesome. The conveyance, of course, must always be down hill when open flumes are used, and a grade of 3 or even 4 per cent is desirable.

135 Where a natural supply of water from an elevation is not available a centrifugal pump may be used. The Hell Gate plant is an excellent instance of this kind, and the general layout is shown in Fig. 30. This is a system of open flumes within the boiler room continuing through a closed pipe to the ash settling tank. Tributary flumes are carried along below each line of boilers and empty into a main cross-flume which runs along the boiler room wall near the turbine room. This main flume then turns and becomes a full pipe or enclosed conduit leading to a pit near the river side into which it discharges. The ashes are recovered from this pit by a grab bucket operated by a locomotive crane running on

a track laid on the pier, and discharged into scows. The scows are towed out and dumped at sea about five miles east of Sandy Hook, or about thirty miles from the plant.

136 The flumes within the boiler room are of concrete with a bottom lining of vitrified earthen drain tiles or half-pipes. Those under the boilers are supported on structural-steel framework suspended from the firing floor, while the main cross-flume is carried on steel trestling.

137 A cross-section of the flume under the boilers is shown

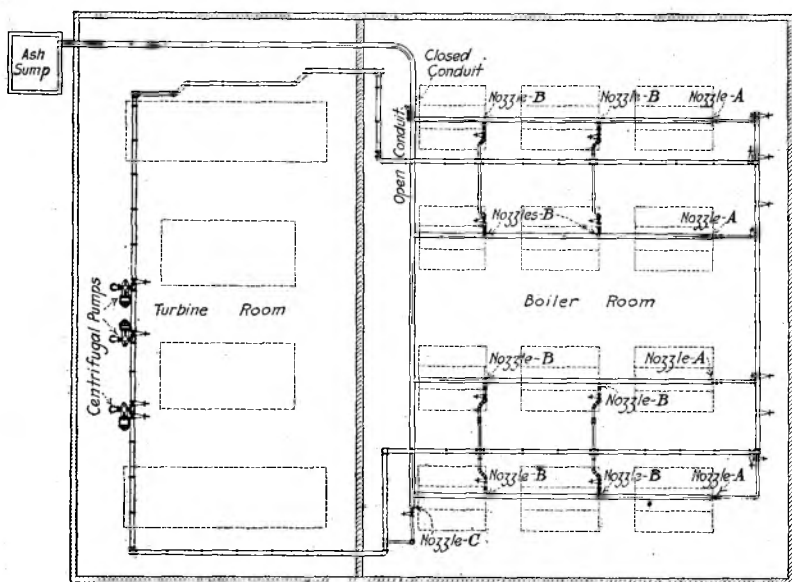

FIG. 30. WATER CONVEYOR AT HELL GATE STATION. PLAN

in Fig. 31. The ash as it leaves the clinker grinders drops directly into the water and is carried away. Access doors lined with common brick are provided so that any obstruction can be handled easily. These doors may be seen in Figs. 31 and 32. Fig. 32 is a longitudinal view of one of the ducts under the boilers.

138 The construction of what may be termed the ash chute, there being no ashpit proper, may be compared with some interest with the unlined sheet-steel chute at Poplar as shown in Fig. 22.

139 The method of water supply is very interesting. There is a nozzle A at the head of each tributary flume, and an ingeniously

arranged undercurrent nozzle *B* at the beginning of each succeeding ashpit. These undercurrent nozzles are at the bottom of the flume and are arranged to discharge horizontally downstream. They are placed to form steps in the flume so that the ash flows over them. They are shown a little more clearly in Fig. 33. At the head of the main conduit is a booster nozzle *C*.

140 The water for the various nozzles is taken from the

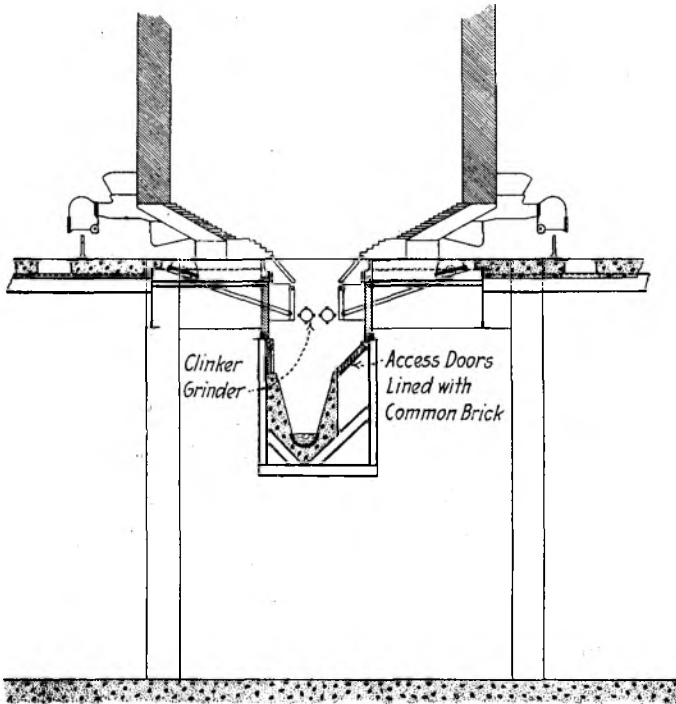

FIG. 31 WATER CONVEYOR AT HELL GATE STATION. CROSS-SECTIONAL ELEVATION

circulating discharge tunnel and is supplied under pressure by 12-in. Lea-Courtenay centrifugal pumps direct-driven by Westinghouse motors. These pumps are single-stage double-suction volute pumps and supply 5000 gal. per min. against a head of 75 ft., operating at 81.5 per cent efficiency. The motors are rated at 150 hp., but the pumps require only 125 hp. under regular operating conditions.

141 The main pipe line which supplies the water nozzles has a bore of 16 in. and is arranged as a ring, as clearly shown in Fig. 30.

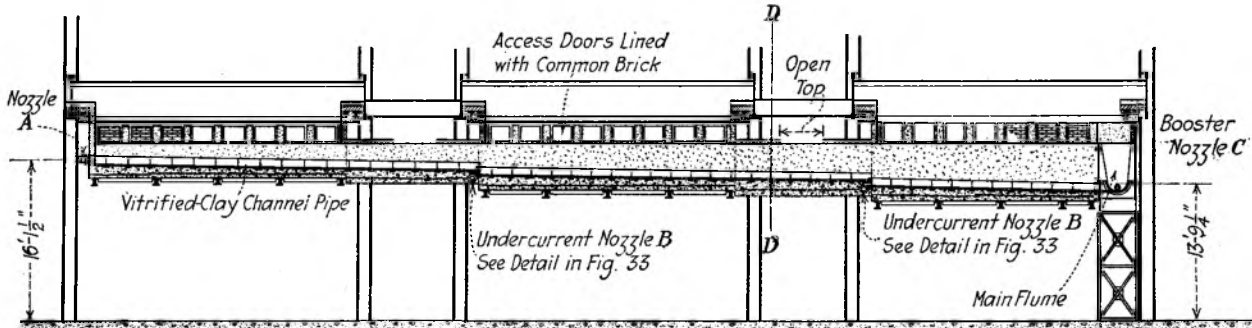
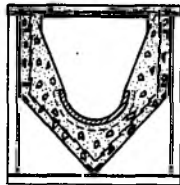

FIG. 32 WATER CONVEYOR AT HELL GATE STATION. ELEVATION OF TRIBUTARY FLUME

Gate valves are placed in such positions that either side of the ring can be shut off for repairs. The three pumps are connected to the ring, with valves so disposed that any or all of the pumps may supply either side of the ring main and any one or two of the pumps may be isolated for overhauling without interrupting the supply of water. The valves controlling the supply of water to the individual nozzles are located in the basement convenient to the flumes, so that adjustment of the flow of water along the flumes can be made very easily and quickly.

142 The system has not been sufficiently long in operation to



Section on Line *D-D*

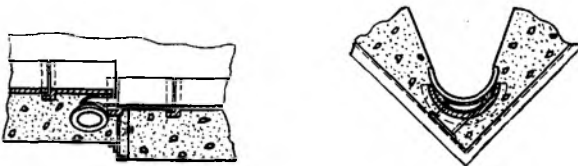

FIG. 33 WATER CONVEYOR AT HELL GATE STATION. DETAIL OF NOZZLES AND FLUMES

determine maintenance costs. The only operating charges are the wages of the ash-crane operator and the cost of energy for driving the pumps. Either one or two pumps are operated according to load and quality of coal.

143 It will be noticed that these ashpits are not sealed, but with the amount of ash lying on the clinker grinders in usual operation, any serious excess air is not to be expected with the forced-draft stokers used.

144 Fig. 34 shows the general arrangement of the ash-slucing system of the Lacombe station of the Denver Gas and Electric Light Company, and a cross-section of the flume under the boilers

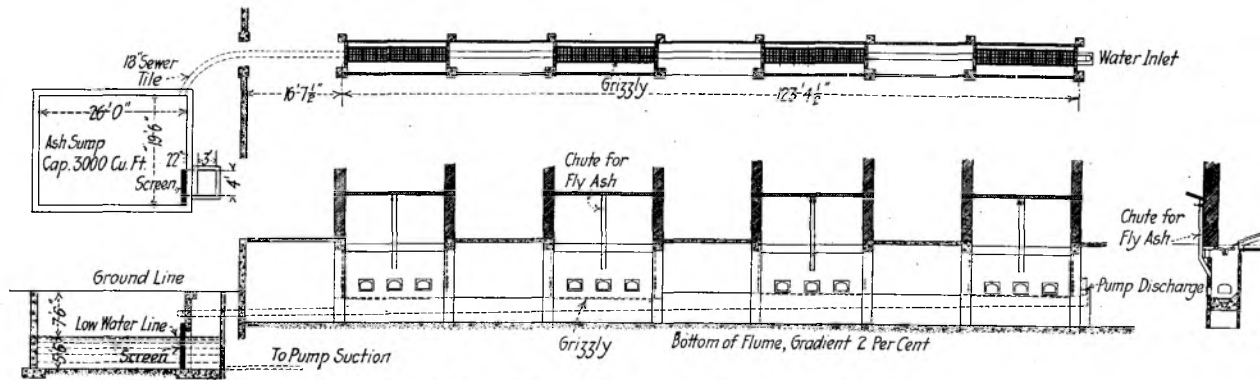

FIG. 34 WATER CONVEYOR AT LACOMBE STATION, DENVER

is shown in Fig 35. The outstanding difference between this plant and the one at the Hell Gate station is that there are no clinker grinders. Consequently, instead of the ground ash dropping into the flume continuously, the stokers are dumped at intervals, sending down a considerable bulk of ash containing large clinkers.

145 As a result, the flumes are protected by a "grizzly" composed of heavy bars set 6 in. center to center to withstand breaking up the large clinkers until they can drop between the

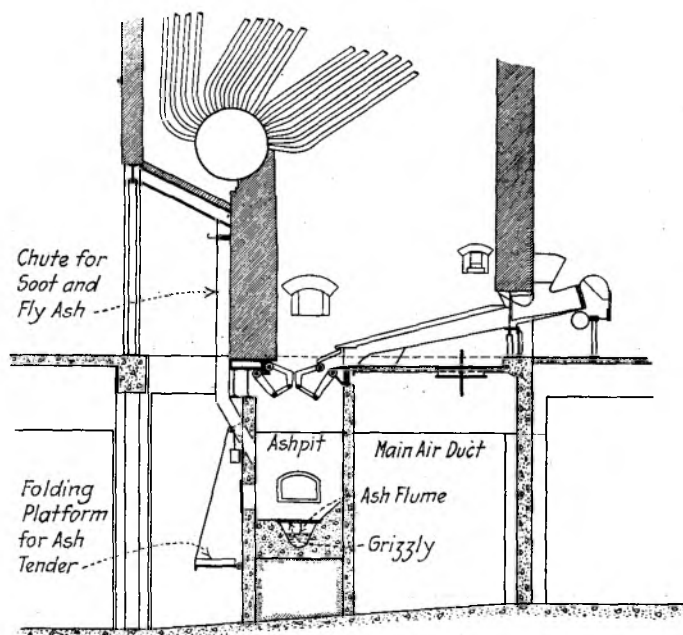

FIG. 35 WATER CONVEYOR AT LACOMBE STATION, DENVER. CROSS-SECTIONAL ELEVATION

bars into the flume. Extremely large clinkers would stop up the flume, but it is interesting to observe Fig. 36, which illustrates some clinkers which have actually passed through the flumes. The water stream will easily handle clinkers about 12 in. square and 15 lb. in weight.

146 The grizzly is made in sections, there being seven sections, each 30 in. wide, to each boiler. Any or all of these sections can easily be removed to give access to the flume.

147 Water sprays cool the clinkers which are caught on the grizzly. The water sprays are discharged from 2-in. pipes which run the full length of the ash hoppers, and which are drilled with  $\frac{1}{4}$ -in. holes on 3-in. centers. As the holes of one pipe are staggered relatively to those of the other, a spray of water is directed across the hopper every  $1\frac{1}{2}$  in.

148 Side-hinged doors 18 in. by 23 in. are provided through which the clinkers can be managed. There are three doors at the rear of the flume and one door at each end under each boiler. These

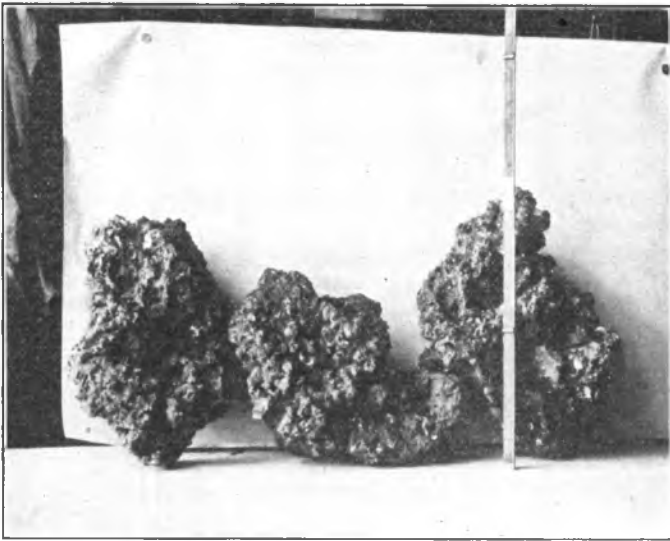

FIG. 36 CLINKERS CARRIED BY WATER CONVEYOR AT LACOMBE STATION, DENVER

doors may be seen in the figures. It is wise to allow ample access to the flume to remove any obstruction, such for instance as might possibly be caused by ashes being inadvertently dumped while there was no water flowing, or by a fall of firebrick, since firebrick cannot be sluiced.

149 The station contains five boilers of 750 hp. each, operated at 250 to 300 per cent of rating. The coal is a sub-bituminous containing 6 to 7 per cent of ash. As the boilers are in line, the flume is single and straight. It is all of 2 per cent grade except the curve to the ash-settling tank, which is of 18-in. vitrified sewer

pipe laid horizontally. The flume and sewer pipe is about 155 ft. total length. The capacity of the settling tank is 3000 cu. ft.

150 The water passes through a screen and is recirculated, and a 2-in. line is used to replenish occasionally the water in the system. The water is circulated by a 6-in. American open-runner centrifugal pump driven by a 20-hp. motor. The pump delivers about 1100 gal. per min. against a head of 25 ft. The system deals with about 33 tons of ashes in 24 hours.

151 The stokers are dumped at intervals of two to two and one-half hours. Water does not flow continuously. When the fireman is about to dump ashes the pump is started, and when the

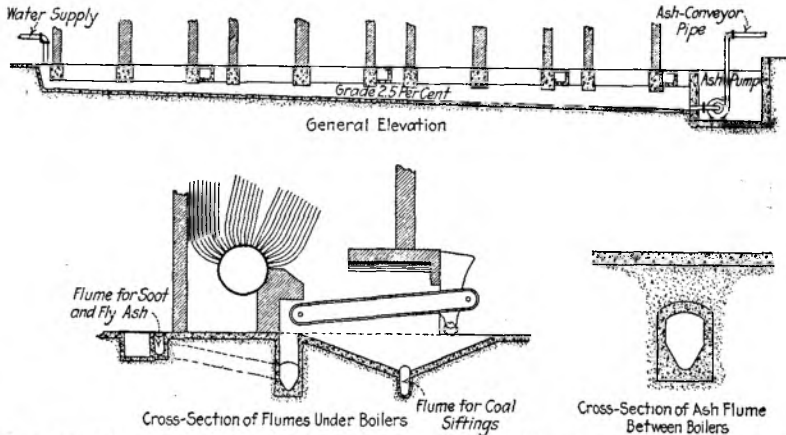

FIG. 37 MORRISON'S WATER CONVEYOR AT GREAT WESTERN SUGAR REFINERY, DENVER

sluiceway is filled with water the ashes are dumped from one boiler at a time into the swiftly moving water. A whistle signal is in use between the fireman and the ash tender. The ashes are recovered from the settling tank by grab bucket and given to the city for suburban road making. Railroad facilities are also provided so that cars can easily be loaded by the grab bucket.

152 Three combination men, one on each shift, are required to handle the ashes and attend to the feed pumps; and about one-third of each man's time is devoted to ash handling. Two men, one on each of two shifts, operate the crane and clamshell bucket by which the ash is recovered from the settling tank. Each man spends about one hour moving ashes.

153 An ingenious arrangement is that invented and patented by Mr. Morrison, of the Great Western Sugar Company of Denver, and installed in several of their plants. An example is partly illustrated in Fig. 37. A flume into which the ashes are fed is arranged under the boilers as in other water conveyors. This flume carries the ash-laden water into the suction connection of a centrifugal pump which discharges into the conveyor pipe. The conveyor pipe is of cast iron, 6-in. bore. Abrasion occurs slowly, but is confined to the bottom of the pipe. It is found that by rotating the conveyor pipes through an angle of 90 deg. every few years, maximum service is obtained out of each renewal.

154 The most serious expense would seem to be that caused by abrasion of the pump; but it has a manganese-steel lining, and the authors are assured that renewal of this lining and of the pump shaft are only necessary at long intervals. These installations are highly satisfactory, and the ease with which the ashes are handled far outweighs the maintenance cost.

155 The discharge pipe from the pump should not slope downward, as it is then found that the water has a tendency to run away from the cinders which remain in the pipe and cause a stoppage. When the discharge pipe is laid horizontally or sloping upward, no such trouble occurs.

156 In the installations so far made the ashes are discharged into natural depressions near the plants. There are plentiful natural water supplies so that there is no necessity to recirculate the conveying water. But it would appear that the discharge pipe could be led into an elevated hopper which would act as a settling tank. The clear water from an overflow could then be carried back to the head of the ash flume. When the pump was stopped and the tank drained, it could be emptied into railroad cars or motor trucks. Such a tank should probably be equipped with a fairly large dumping door as the ash would tend to pack rather tightly.

157 In designing a water conveyor it must be borne in mind that while continuous dumping stokers such as chain grates or those equipped with clinker grinders may discharge directly into continuously running water, dumping stokers or any firing system where large clinkers are to be expected should discharge on to a grizzly of massive bars on which clinkers may be broken small. The water need only be running while dumping is in progress with stokers of the dumping type.

158 Concrete troughs, if carefully built, will be found to require very little repair. The inside lining should be smooth and free from pits.

159 There should be a plentiful supply of water under a few pounds pressure. About 1000 gal. per min. should be supplied for each flume.

160 With natural draft, means should be devised to provide seals so as to prevent too great an excess of air from passing up through stoker dumps.

161 When the water is recirculated, the pump should be designed to handle gritty water, and occasional renewals due to this reason must be expected, though they will not be serious.

162 As there is often considerable dust and gas generated with stokers of the dumping type, it is advisable to provide the access doors with latches so that they cannot be blown open. Ample ventilation near where ashes are handled should always be provided.

163 While but little attention is necessary with this method of handling ashes, it is well to have a man told off for the purpose. One man can attend and clean the circulating water screens, supervise the sluicing of ashes, and generally act as boiler-room janitor.

164 In some localities in winter, trouble may be expected from water freezing in the bearings of grab buckets. In particularly cold situations the wet ash will freeze in the cars and cannot be dumped unless it is thawed out. Weather conditions may therefore prohibit water conveyors in some instances.

#### ASH DISPOSAL

165 As mentioned when describing methods of conveyance, ashes are often used to fill depressions around the plant, but this cannot go on forever and means must be adopted to get them away from the vicinity. Some highly fortunate persons are able to sell them, but most are glad to be able to give them away. It is of great advantage in both of these methods if the ashes are loaded into an overhead bunker of some kind which will discharge by gravity through dumping doors into carts and motor trucks. People taking the ashes away prefer to patronize those plants where their trucks can be filled quickly in this way rather than to spend the time and money to shovel them from a heap on the ground.

166 But the ashes must be got away somehow, and if they

cannot either be sold or given away, they must be removed by rail or by boat. They must not be dumped into rivers, partly because of pollution and partly because of choking the river bed against water flow and against navigation. If removed by rail, they are usually dumped finally into natural or artificial depressions, etc., where filling in is desired or tolerated, such as ravines and abandoned mines.

167 At some of the plants of the West Penn Power Company it is intended to carry away the ash by aerial tramways or ropeways as far as 3000 ft., where it will be used to fill up ravines to a height of from 200 to 300 ft. At the Windsor plant, where ashpits similar to those of Springdale as shown in Fig. 16 are to be installed the bucket will dump the ashes into a hopper feeding a belt conveyor which will discharge into an outside tank from which the aerial-tramway cars will be loaded. At the Springdale plant the ashes will be loaded from the bucket into a traveling hopper which will discharge into the aerial cars without any connecting link.

168 Some public-utility companies have a number of isolated plants used for the supply and sale of steam for heating, which take all their electrical requirement from the central station. In one such instance in the Middle West the ashes are collected in trucks and wagons and hauled to a point on a railroad siding. An elevated ash bunker having a capacity of two railroad cars was erected here at a sufficient height to discharge ashes into the cars. A bucket elevator was installed at the side of the bunker, with the boot below the ground level. A grating was placed level with the ground and over a hopper or chute leading into the elevator boot, and the trucks and wagons drive over this grating and dump the ashes through it. This is a very convenient method of disposing of ashes from a number of small plants as no delays are encountered by wagons waiting to unload.

169 Plants near the coast can sometimes dispose of their ashes by loading them into dump-bottom barges which are towed out to sea for a prescribed distance, where they may be discharged. This method is practiced by the Hell Gate plant as already described.

170 The ashes are sometimes used for making suburban roads. When in small enough pieces such as will pass a  $\frac{1}{2}$ -in. or  $\frac{3}{4}$ -in. screen, they are often used for making cinder concrete.

171 In considering any new station, the ultimate disposal of

the ashes is one of the first things to be considered, because the ash-handling equipment can then be devised so as to accommodate itself thereto in the simplest manner.

### CONCLUSION

172 Costs of equipment, maintenance, or labor have not been included, although numerous cost figures have been collected, some giving very exhaustive details of cost of installation and operation. Such figures are of absolutely no value for comparison as between one station and another, or as between one system and another, and are likely to do more harm than good. So many circumstances enter into any particular problem that any figures offered for comparative purposes should be used with great caution. Wide experience and sound judgment are far more valuable in this work than bald figures, and therefore no tabulation of costs of any kind has been attempted.

173 The primary object of any modern system of ash handling is to reduce labor costs to a minimum. Any scheme must conform to this requirement; and then must conform to the further requirements of low depreciation and maintenance.

174 The method of ash handling adopted for any plant will be governed by the way in which the ashes are delivered from the fire and by the facilities for final disposition. It may even be the case that a system must be so devised as to meet efficiently an intended change at either or both ends. Reasons may exist compelling the method of firing to be changed some time after the ash-handling system has been installed, and the same thing may apply to the final disposition of the ashes. The prudent engineer will examine into future as well as present requirements.

175 The endeavor has been made to present sufficient description and illustration of all the successful methods of handling ash in such a manner as will enable those interested in the subject intelligently to design or criticise almost any installation with which they may be confronted.

176 In conclusion, the authors desire to express their grateful acknowledgment of the ready and courteous response of those connected with both manufacture and operation when requests for information were made.

## DISCUSSION

T. A. MARSH. For a long time, power plant designers have felt the need of a comprehensive treatise on ash removal and disposal. Power plants are frequently successes or failures, depending upon whether a good ash disposal system or a poor one has been installed. This refers not only to the type of equipment for handling the ashes, but the design of the ashpits or hoppers, their capacity, the valves, the quenching system, and in fact all of the details that go to make up the success or failure of the system.

Designing engineers and consulting engineers, building power plants frequently, have had some basis to govern their designs, but the occasional builder of power plants, such as the average industrial company, has been without any text or data to assist in this important feature of power plant design.

From the standpoint of the stoker manufacturer, ashpit design is extremely important, as faulty ashpits have contributed more to the failure of stokers than any other single item, except, perhaps, draft.

Par. 82 and those following describe a type of cross conveyor used extensively in England and gaining great popularity in this country. These conveyors can be installed where the head room is limited. They are built very ruggedly and are producing wonderful results. In the large central stations, the application of this type of conveyor permits the reduction of head room in the basement, thereby saving materially on initial cost, and on operating heights for elevating coal and other material.

Referring to Par. 103, on air conveyors, it is a question as to whether it is desirable to use conveyors larger than 8 in. in diameter. The average capacity of a man hoeing ashes to an intake is five to six tons per hour. Eight-inch systems will handle seven or eight tons per hour, but are invariably limited by the ability of the operator to get the ashes to the intake. Therefore, increasing the size of the conveyor pipe does not proportionately increase the capacity of the ash-handling system.

Remote control, mentioned in Par. 108, for shutting off steam when the system is out of use, is being received with great favor. In the average system about twice as much steam is used as is actually required for handling the ash, the excess steam being

that which is consumed while ashes are not actually hoed into the intake.

Another very important item in air system design and operation is the wear of steam nozzles. So far no metal has been found that will resist this wear for a long time. A very slight increase in the diameter of a nozzle, of, say,  $\frac{1}{4}$  or  $\frac{3}{8}$  in. diameter, increases the steam consumption enormously. This makes the steam consumption disproportionate to the ash handled, and creates too high a velocity throughout the system, thereby causing excessive repairs and usually discrediting the ash system from the basis of poor steam economy and high maintenance.

The thin shell-like nozzle is the safest and surest design to prevent these troubles, for it is impossible to increase the steam consumption with this. The nozzle simply wears through and can be quickly replaced. The cost of such nozzles is but a small fraction of the cost of the solid hardened metal design.

F. B. ALLEN. The ordinary system of quenching ashes is to introduce one or two pipes, perforated with a series of holes, running the entire length of the hopper. Water is then connected to these "spray pipes" and squirts out of them in a series of jets. The most serious objection to such a system is its failure satisfactorily to quench the ash, unless a tremendous excess of water is used. An inspection of such a system in operation clearly indicates the reason. Each jet wears a small channel through the ash to the gate beneath. The water cools the walls of its particular channel, leaving the rest of the ash unquenched. This is strikingly checked by feeling of the water as discharged from a hopper thus equipped, which will be found to be lukewarm; if then the inside of the hopper is inspected, it will be seen that a great portion of the ash is still incandescent.

Much better results may be obtained by running the quenching water header outside of the hopper with a series of off-takes to quenching nozzles located through the hopper walls. These quenchers are designed to spray the water in fine particles evenly over the ash. There will then be no channels worn through — each drop of water will cool its quota of ash.

Another serious objection to the use of perforated pipes is the clogging of the perforations. As a result, the water distribution is, of course, even poorer and often the quenching system is virtually shut down. When these perforations do clog, nothing can ordinarily

be done about cleaning them until the boiler is shut down and the pipe can be cleaned from the inside of the hopper. Another objection is the inability of the operator to control the water quantity entering the hopper, for the reason that plant pressure is ordinarily connected to the spray pipe, the water supply being controlled by a valve. If the line is throttled by this valve, the pressure of the pipe is reduced and the water merely dribbles from the opening. A system of spray pipes within the hopper is subject to rapid deterioration resulting from their constant contact with hot sulphurous gases.

Where a series of quenching nozzles are used, each independently controlled, the water discharge from the quenchers may be controlled over a wide range by throttling, with little effect on the distribution, or alternate quenchers may be entirely shut down, the others giving very satisfactory water distribution for lighter loads.

It may be argued that these quenching nozzles will clog, making them ineffective. Such trouble is very simply met by connecting each quencher through a  $\frac{1}{2}$ -in. valve to supply header. Thus any quencher may be shut down. The quencher is so designed as to have a minimum orifice of  $\frac{1}{4}$ -in. diameter and should this clog, it is possible to clean it from the outside of the hopper by removing a 3-in. acid bronze access plug. This can be done without disturbing the operation of any other quencher and while the boiler is in operation.

With a series of quenchers located in the walls of the hopper, the quenching header is of course outside of the hopper and is therefore not subject to the deteriorating effects of contact with hot sulphurous gases.

It is the writer's opinion that ashes should be continuously quenched. Probably this opinion will not meet with much argument where the ashes are dumped continuously, as is the case with chain-grate stokers, or underfeed stokers with clinker grinders. In such cases, the ashes are discharged to the hopper continuously and it is logical to quench them continuously. Where the ashes are discharged intermittently from dump plates, particularly in connection with underfeed stokers, it is probably advantageous to reduce the amount of continuous quenching water perhaps 50 per cent; using the additional 50 per cent of water for only a comparatively short time after each dump of the stoker.

Continuous quenching with the water introduced by means of nozzles requires but from 3 to 5 gallons per minute per hundred rated horsepower of the boiler; the pumping expense is therefore

small, while the advantages are considerable. If the ash gates beneath the hoppers are designed with a very small amount of clearance between the frame and the movable door, the quenching water will build up a slight head in order to force its way through this opening. Manifestly, if there is 1 or 2 in. of water on the top of the gate, no air can enter the hopper around this opening and the hopper is water sealed. The arrangement results in continuously cool ashes, meaning a minimum up-keep of stoker parts at the dump end. It also means a maximum combustion efficiency as there is no excess air leaking into the furnace from the ash hopper which is water sealed.

A wet and sloppy ash aisle beneath is obviated by use of an ash gate which collects this water as it flows from the hopper and discharges it to drain, thereby maintaining a clean, dry basement.

NEVIN E. FUNK. Ash-handling systems can be divided into two divisions. One class is easy to operate, may be readily repaired in parts without putting the entire system out of commission, and if it does fail some other device can be substituted for it without putting the boiler plant out of service. Lastly it is flexible and can be used for greater capacities than originally intended. The apparatus of the other class is the antithesis of the first. It is not flexible, when repairs are necessary at least one section of the boiler room is out of commission, other methods cannot be substituted for it, and it is generally of greater initial expense and may be more expensive to maintain.

In the first of these two classes the writer would include the railroad car, the industrial railway with storage battery or trolley locomotive, and perhaps the water-sealed ashpit of Fig. 16 with a crane for removing the ashes. In the second class should be included all air, hydraulic and mechanical conveyors.

The difficulty of raising the boiler room to accommodate railway cars is not so serious. There is not much more room required with such a system than with some others, as it is possible to drop the basement where the cars come in.

The author says in Par. 26 that the "largest ashpit capacity will be requisite with conveying systems that are operated intermittently." This is predicated on the fact that the continuous system operates all the time, which it does not. There must be sufficient storage to provide for the intermittent operation caused by breakage.

The system illustrated in Figs. 20 and 21 is for both coal and ash. Coal has enough ash in it without the addition of ashes which may drop into it from the buckets of this system.

The water-seal chain and cross-bar conveyor of Fig. 22 does not look promising from an operating standpoint. It does not seem possible that one chain would break without breaking the one beside it, and with a boiler in operation it would be hard to repair the conveyor.

The air conveyor with vacuum storage tank, illustrated in Fig. 23, makes a good water gas generator which is likely to explode. Also the system is a hard one to keep tight, and the wearing backs are not the only parts that wear.

The hydraulic system of Fig. 30 looks as though it would put three boilers out of commission in event of failure, and while the flotation of ashes by water relieves some of the weight so far as friction is concerned, there is still abrasive action.

With the railroad car or industrial railroad, more cars can be used if the ash content of the coal increases. The cars can be pulled out by horses in case of breakdown, and if the rails break it is possible to send trucks into the basement to carry the ashes away.

NIXON W. ELMER. A good many engineers feel that we are entering an age of powdered fuel. The powdered-fuel ash problem is different, and requires considerable study.

I. E. MOULTROP. Of the three big handling problems of the modern power plant, — water, coal and ashes — that of the ashes is the most perplexing. But the ash problem of a big plant is not the handling but the disposal.

The first problem of ash handling is to provide a big ashpit. It cannot be too big. Ashes should be handled with the least amount of machinery possible, and the machinery should be such that, in case of breakdown, it does not interfere with the disposal of the ashes. The railroad or the industrial railway have the advantage that in case of breakdown the ashes can be dumped on the floor.

T. MAYNZ. The problem of disposing of ashes in a large station is a difficult one, and it is important to have a space sufficient to store the material. In our plant there are industrial cars and a skip hoist. In case of a breakdown, the ashes are dumped on the floor which fortunately will accommodate 48 hours' supply of ashes.

The problem is not to cut down on head room in ashpits but to give them all the room possible.

SAM H. LIBBY. One of the greatest problems of a designing engineer is to find out all the details of what is expected of the machine he is designing. Recently a machine was supplied to a concern who said that their coal capacity was 20 to 40 tons of coal per day. The machine was designed for this capacity, with allowance for an ample margin but it broke down. Investigation showed that the coal was bought in train-load lots arriving at the plant in lots of six or eight cars at a time, and unloaded as rapidly as possible to save demurrage. The machine built to handle 40 tons per day was consequently handling 250 tons.

E. H. TENNEY. The disposal of ashes from numerous isolated power plants, such as office buildings, hotels, etc., in the down-town district of the city of St. Louis has had considerable attention by the writer. Practically all types of systems are in use, each being adapted to its own particular requirements, such as, wheel barrow, bucket hoist, hydraulic lift, motor-driven lift, air ejection system and the link-belt system described by the author in Par. 70.

In connection with the use of air ejector systems in down-town districts, we found, that other things being equal, a great deal of consideration had to be given to the prevention of dust. In the particular installation in mind, this was eliminated by the careful design of water spray rings and the proper installation of a stand-pipe vent on the ash receiving tank. We have also found that where ash hoppers are located outside the plant so that trucks or other conveyances can drive beneath them, for loading purposes, considerable difficulty was encountered in the winter, due to the ash gates freezing. This difficulty was easily overcome by the installation of small steam lines on all such ash-hopper gates for the purpose of thawing them loose. This point should not be lost sight of in building overhead ash hoppers where the question of hurried ash removal is necessary, as is the case with office building or hotel power plants.

The writer agrees with the authors as to their conclusion in that each handling problem must be given its own due consideration and that what is good for one station cannot be acclaimed good for another, and for this reason the presentation of the means and methods employed by others, as set forth in the paper, readily

visualizes the many schemes possible, and no doubt should prove very helpful to those considering ash-handling problems.

RANKIN EASTIN<sup>1</sup> wrote a description of an hydraulic ash-disposal system installed by him at the Tell City Water and Light Co. An 18 by 18-in. sluiceway was constructed of concrete beneath two boilers (one 406-hp. Heine and one 250-hp. Atlas) in such a way that the ashes fall into it and are carried out onto a catch platform where they are separated from the sluice water and stored for use. In case there is no demand for the ashes they are allowed to discharge into the river with the sluice water. Water for the system is derived from the waste water from condensers. Emergency water connections with water at 70 lb. pressure are also provided. Eight-inch connections to the sluice are provided for soot and fly ash from the rear of the boilers.

R. H. BEAUMONT. The writer's conception of a modern ash handling system is that it must be capable of meeting the following requirements:

- 1 It must be capable of handling very large clinkers
- 2 It must be of such design that abrasion has little or no effect on its parts, so that repairs are negligible
- 3 It must not consume much power, nor waste it running idle
- 4 It must be capable of lifting the ashes to a good height without being subject to excessive wear by so doing
- 5 It must handle either red hot or dripping wet ashes with equal facility
- 6 It must operate without making dust or exceptional noise
- 7 It must be capable of handling ashes at a high hourly capacity
- 8 It must handle the general run of boiler room refuse, such as soot, flue dust, broken bricks, broken grates, etc.
- 9 It must be capable of taking care of plant extension without having to be completely remodeled
- 10 It must deliver ashes into the storage bunker in such a condition that they are acceptable to the railroad as freight.

The writer was disappointed with the casual mention of what is the most important device used today to handle ashes —

<sup>1</sup> Supt., Tell City Water & Light Co., Tell City, Ind.

the automatic electric skip hoist. However, while but slight space is given to it, it is pleasing to note that it is a very satisfactory device, and no faults are to be found with it. In fact it is the only popular device described in the paper which seems to get a clean bill of health.

The fundamental idea is covered by Par. 173 wherein it states that "the primary object of any modern system of ash handling is to reduce labor costs to a minimum." The ash hoppers are part of the system and should be proportioned with this fact in mind. In general they should have enough capacity so that all the ashes produced in 24 hours can be easily handled by the day shift, which means somewhat over 16 hours and preferably 20 hours storage based on a safe percentage of ash content.

The writer wishes to modify the statement made in Par. 26 that where a continuous conveyor system is used, the hopper may act merely as a funnel or chute to guide the ashes into the conveyor. Of course, it may, but this means that ashes must be handled continuously every shift and also that no time is available to repair the conveyor. The hopper must still be proportioned to save labor if the fundamental reason for installing the system is not to be violated.

Continuous conveyors for ashes cause complete paralysis when they break down.

Care must be taken to design the hopper to fit the system. For instance, bottom dump hoppers with large gates five feet square will frequently empty the hopper too quickly. This would not be objectionable if the hopper were discharging into a railroad car or large truck, or any other container that would take the entire contents. In this case the gate is not used to control the flow of ashes, but rather to close the bottom against the time of discharge. But suppose the hopper, holding 20 hours' production of ashes, discharges into a small industrial car. It then becomes very necessary to control the rate of flow in order to prevent flooding the car.

A design of hopper with gravity discharge and at the same time having perfect control over the flow of ashes is shown in Fig. 38 where the outlet gate is set at an angle of 45 deg. which is also the angle of slope the bottom plate.

Par. 35 states that steel-plate hoppers are undesirable owing to rapid corrosion and therefore it is best to use cast iron. Steel-plate hoppers have been in service many years, while the cast-iron hopper is a very recent innovation and consequently it is impossible

to state with any assurance that it is better. The writer believes that plate hoppers,  $\frac{3}{8}$  in. thick, made of pure iron and protected with bitumastic enamel between the plate and the brick lining are better than cast iron. Hard burned or vitrified paving brick is better than firebrick for lining the hoppers.

Cast-iron hoppers are supported by a steel framework, which

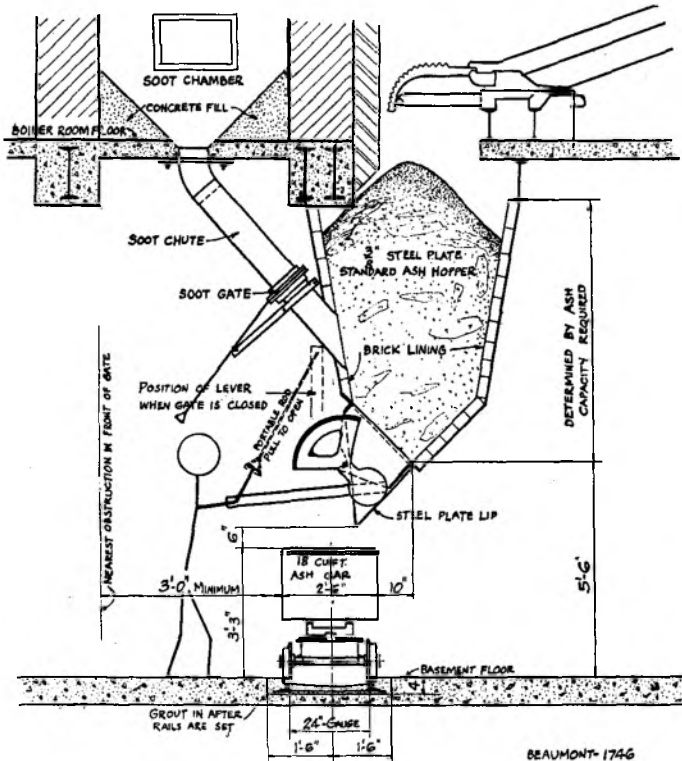

FIG. 38 HOPPER WITH GRAVITY DISCHARGE

in turn is attached to the boiler beams by suitable connections. In comparing them with steel plate hoppers, it must be remembered that the horizontal sectional area of these connections is very small whereas the steel-plate hopper is continuously supported all around. In other words, how much supporting metal must be corroded in either case before the hopper can drop to the floor.

Referring to the push cars which are shown in a number of the illustrations, my experience has been that the most one man

can push is 20 cu. ft. Wherever a larger push car is used, two men will be found pushing it even though the designer of the system intended it to be a one-man car.

The modern tendency is to use an electric ash larry of 50 cu. ft. capacity, designed with ample power to haul about three additional trailers each of 50 cu. ft. which may be added one at a time as the plant grows. These electric ash larries with their trailers are bottom dumping and designed so that the gate trips automatically when passing over the dumping point. A representative layout of such an ash larry and trailers is shown by Fig. 39.

The writer believes that the ash larry, used in connection with an automatic skip hoist, the entire system being operated by one man, is today the most widely used ash-handling method, for medium and large-sized boiler houses because it better meets the factors which must be met to secure a good ash-handling system, as mentioned in the first paragraph of this discussion. No conveyor manufacturer fostered it. In fact, it was developed and applied to a Philadelphia Rapid Transit Co. power house in 1897, to replace the rather crude chain elevators and conveyors then in use. Another installation made about 1908 was at the Lardners Point Pumping Station of the Philadelphia Water Works which is still in service. Some of the very oldest stations of the New York Edison Co. used skip hoists.

The question of large clinkers is a serious one and is recognized as such in the paper under discussion, but the problem is not to be solved by merely providing something to prevent clinkers entering the system. Of what use is it to put gates five feet square under the ash hoppers in order to pass these clinkers and then make the remainder of the system capable of handling only fine ashes.

Mention is made in Par. 118 of the justly famous Lakeside plant of the Milwaukee Elec. Ry. & Light Co. which uses an air conveyor. It is interesting to note that a year or so ago a skip hoist was installed to handle the clinker or slag.

It is not stating the case correctly to say that there are no moving parts to an air conveyor of the steam jet type. In this case, it is entirely justifiable to say that the entire system is one immense moving part, as movement is relative, and it is certain that the ashes are rushing at a great rate through the pipe. The relative movement between the pipe and the ashes certainly ought to be taken into account. With a car and skip hoist system there is no relative movement between the car or skip bucket except when

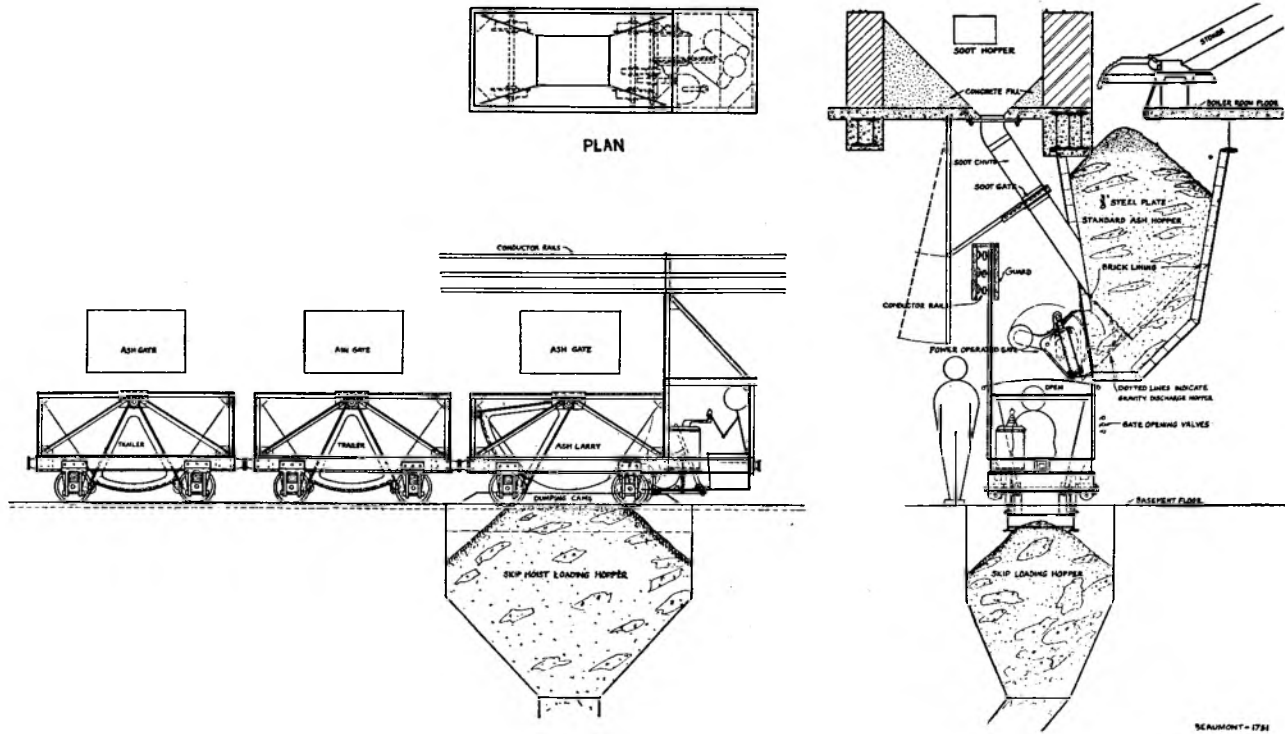

FIG. 39 LAYOUT OF ASH LARRY AND TRAILER

SCALMONT - 1781

loading and discharging and even then, the amount of ash in sliding contact with the plates is but a small percentage of the total amount contained within the bucket. During the transfer from hopper to bunker the ashes are absolutely at rest in the car or skip bucket.

A brief description of a new steam station of the Electric Bond and Share Co. might be of interest. The ash car is electrically operated, capacity  $2\frac{1}{2}$  tons and the entire side opens so that the large clinkers will easily pass through. The skip bucket is three tons capacity so that it can take an entire carload.

The winding machine is spur geared type with gears enclosed and running in oil, and the entire machine is located in a clean space on the operating floor of the boiler room.

The control is Cutler-Hammer, and the skip is semi-automatic in operation, that is, the bucket performs a complete cycle starting from the pit ascending, dumping, reversing, descending and coming to rest in the pit. This control is placed on the winding machine itself and switches at the top and bottom of the runway for operating the skip are omitted. There is a safety switch at the top but it functions only as such. The ash bunker gates are all 48 by 60 in. and air operated.

GEORGE G. BELL.<sup>1</sup> Ash-handling troubles depend to a great extent upon the type of coal burned. Coal having a low percentage of ash which has a high fusing point will give comparatively little trouble; whereas coal with a high ash content, which fuses in the neighborhood of 2000 deg., cannot be handled with the same freedom from trouble; and the maintenance of the ash-handling equipment is certain to be very much higher than with the better class of coal.

The additional labor and maintenance resulting from burning coal containing a large percentage of ash having a low fusing point is caused by the formation of clinkers in the retorts and on the dump plate or clinker grinder pit as the case may be. Clinkers invariably result in an increase of the amount of coke in the ash. The practice mentioned by Mr. Hunter of admitting air to the ash-pit in order to reduce the amount of carbon in the ash is objectionable, as such burning out in the ash-pit is apt to form a large clinker, which may bridge across the ash-hopper gate and require the use of slice bars to break it up before the ashes can be removed. If the ash is allowed to fill the pit till it comes in contact with the

<sup>1</sup> Mgr., Power Development, West Penn Power Co., Pittsburgh, Pa.

wind boxes and stoker dump grates, the maintenance on these parts will be exceptionally high.

The problem of properly quenching ashes is a difficult one. There is a great deal of trouble with nozzles; those giving the best results are probably of home-made construction, the holes being of liberal size. It is advisable to provide facilities for cleaning spray pipes with the boilers in service.

The combustible and corrosive gases, generated when the hot ashes are sprayed with water, will produce a pressure in the pit; and unless the ashpit gate has a water seal, these gases will be discharged into the ash cellar. With a sufficient water seal, the gases will be forced to escape through the dump grate into the combustion chamber, where the unconsumed gases will be mixed with excess oxygen and consumed. A water-sealed ashpit also prevents the clinkers formed over the nose of the stoker deflecting the partially or completely burned gases into the ashpit and out through the ash gate, which may in extreme cases make it impossible to work in the ash basement.

Regarding ashpit capacity, Par. 26 states that a continuous conveyor system will require a smaller ashpit. While this is permissible, an exterior storage of some type will probably have to be provided, in order to take care of contingencies which arise in the final disposal of the ashes. The advantage of a large ashpit storage is that it reduces to a great extent the liability of having to take a boiler off the line on account of the ashpit filling. This capacity should be large enough so that labor troubles will not result in closing the plant in a few hours.

Regarding the capacity of ash hoppers, Par. 27 should include an allowance for the coke in the ash. Some operators claim results as low as 10 or 15 per cent coke in the ash; but few persons would design an ash hopper figuring on less than 25 per cent.

The necessity of providing for the handling of large quantities of ashes together with the rapid deterioration of the iron work due to the corrosive action of the gases and the destruction by the ignited gases of the ashpit doors led to the adoption of the water-sealed type of ashpit originally proposed by Mr. Frederick Sargent, in the Springdale plant; and it is being installed in the 1922 extension to the Windsor plant. This later plant was originally designed with a maximum distance of 25 ft. between the top of rail in the ashpit and the boiler-room floor. A small-sized locomotive was used in this ashpit requiring a clearance of about 12 ft.

It was felt that a water-sealed gate was necessary; and when this problem was submitted to the gate manufacturers, and designs were submitted, the matter of the disposal of the water from the clinker grinder and the spray pipes in the ashpits was the main difficulty. The water conduits being small were very liable to clog up with small particles of ash. A comparison of the cost of this type of ashpit and gate with the type of water-sealed pit which could be installed led to the conclusion that the cost of the two schemes would be about the same, and that the water-sealed pit would have ten days' storage as against one day's storage with the other type. This cost included the cost of the cranes for loading out the ashes; but did not include the cost of equipment for removing the ashes from the basement to the outside disposal.

The Windsor arrangement differs from the Springdale arrangement in that a 3-yd. Blaw-Knox bucket is used instead of the 1½-yd. bucket as at Springdale. The bucket moves lengthwise of the building only, so there is not the delay in dropping the bucket that there is at Springdale, as the motion at the latter plant is crosswise of the narrow pit. Also, the trough is continuous, so the water is all carried to a common point, the overflow being discharged into the sewer. The temperature of the water at Springdale remains at about 135 deg. with the boilers in operation. No air is handled through the ashpit basement. This is a matter which is very frequently overlooked in the ventilation of the building; and it is probable that if it was necessary to take air in through the ash basement, there would be less vapor formed from the water-sealed pit than from the ordinary ash hopper with water escaping from the gate. If the air supply for the boilers is drawn in through the ash-pit basement, there is danger of these overflow pipes and even the gates freezing up when the boiler is banked for a long period.

For handling the ashes in the basement of the power house four cranes can be provided, if necessary; this means that each crane will have to handle a capacity of about 100 yd. per hr., or 50 tons. It is probable that if the capacity of this station is increased, the load factor on it will decrease, so it would look as if two cranes would handle the amount of ashes to be disposed of from this plant. However, twice this number can operate to advantage. This will permit of the removal of the ash in a single shift per day. The ashes are discharged by the buckets into a hopper and by means of rubber belts conveyed to an exterior ash

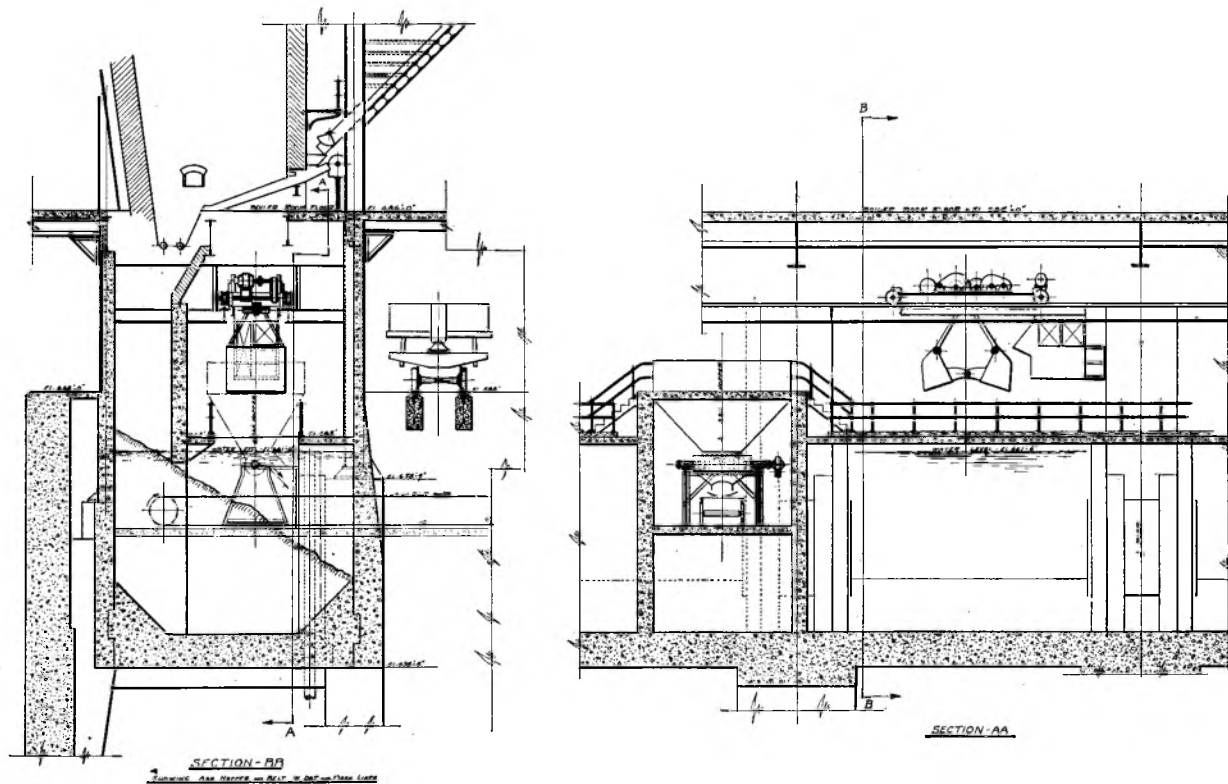

FIG. 40 WATER-SEALED ASHPIT, WINDSOR STATION

tank, from which they are loaded into 35-cu. ft. aerial tramway buckets. The capacity of the ash tank is 110 tons.

Arrangements are made that the ashes from the tank can be loaded into electric railway cars, steam railway cars, or trucks, as well as into an aerial tramway for ultimate disposal in filling deep ravines in the immediate vicinity of the power house. In case the belt conveyor is down, the cranes can discharge directly into railway cars located at either end of the ashpit.

With this system the main boiler-room floor is only 20 ft. above high water in the river; whereas if the ashes were to be dumped into small hoppers having not over a day's capacity, and be dumped from there into railway cars, the boiler-room floor would be located not less than 30 ft. above high water, and probably 35 ft. This reduction in the height of the boiler room can only be obtained without some additional expense in case the foundation for the boiler room is sufficiently below high-water level to permit of the installation of the water-sealed pits.

Mr. Funk stated that he did not know where to place the water-sealed ashpit with regard to reliability. I wish to point out that the same type of ash disposal equipment can be used as with the ordinary ash hopper, that is, railway cars, so this part of the system can be increased in units as the power house is extended; and that the investment in pits, including the cranes for handling, is no more than the expense of the modern ash-gate hopper. In a large power house sufficient cranes can be installed at a total cost not in excess of the ash hoppers and gates to allow for the breakdown of a portion of the equipment. The experience with cranes has been very satisfactory, and maintenance on them very low; whereas, our experience with large air-operated dump gates, handling partially quenched ashes, was very unsatisfactory. Maintenance on the railroad equipment is considerably less with thoroughly quenched ashes; and working conditions in the basement are so much improved that instead of ash-handling being difficult to keep men on, it is considered desirable work.

EUGENE HAHN. In marine practice there are unavoidable losses of fresh water through safety valves, whistles, leaks, soot-blowers, and a number of incidental causes in the operation of a boat. The addition of any other apparatus that should require steam for its operation that could not be returned to the condenser would, therefore, appear to be unwise, unless there were good enough reasons

in its favor. The above unavoidable losses of steam in the operation of a boat are taken for granted, and there is usually a wide margin allowed for them, as the frequency of operation of those elements contributing to this loss of fresh water is highly uncertain. As there is no fixed relation between the horsepower rating of the vessel and the "make-up" water carried in the tanks, it is impossible to state whether the actual loss of fresh water contributable to the above causes is five or ten per cent of the full amount carried in the tanks. However, it is a fact that hardly ever has a vessel run out of "make-up" water due to the losses normally expected from above causes.

As against the uncertainty of the amount of loss of fresh water due to the above causes, the ejection of ashes by steam requires a predetermined amount, depending upon the quantity of coal to be consumed on a voyage, and its percentage of ash. This amount should either be so small that it could be well spared from the supply of "make-up" water carried in the tanks, or, should the supply be already scant, it is to be determined whether the advantages of a steam ash ejector are sufficient to warrant the fractional increase in the amount of fresh water carried in the tanks.

Every now and then we hear about a case where steam has been used instead of water with a hydraulic ash ejector. This usually occurs in case of breakdowns of ejector pumps that could not be repaired promptly during a voyage. However, upon arriving in port, this emergency method is soon discontinued, due to several obvious reasons. The nozzle that was good enough for water is far from the right size and proper design of a steam nozzle and will consequently use several times the amount of steam that it actually should, also with the ordinary hopper arrangements of a hydraulic ejector it is impossible to feed ashes and large clinkers at the greatly increased rate at which a steam jet can discharge the material as compared with a water jet. Also, with the customary design of a hydraulic ejector, it was impossible to utilize the combined advantage of continuous suction and of a steam jet, as against the pressure only of a water jet. Furthermore, the hydraulic ejector, having been able to resist the occasional "in-wash" of a rolling sea, could not operate with a steam jet under identical conditions, unless the height of the ejector was increased and its discharge end re-designed. Upon arriving in port the failure of such an emergency steam jet ejector was still more evident by the soiled condition of the paint, and even the deck of the vessel. This was due to the

fact that, there having been no water ejected with the ashes, the fine dust was permitted to settle on the outside of the boat. The elimination of the very reasons that discouraged the continued use of an emergency steam ash ejector naturally is appreciated by marine engineers, who look for something simple and more economical than the average hydraulic ejector. Such an improved steam ash ejector will, before all, reduce the loss of fresh water to a minimum. Its steam nozzle is designed on the best principles of turbine practice, and to reduce the time during which steam is passed through it, there is an automatic connection provided between the steam line and the starting and stopping of the ejector.

To prevent the scattering of fine ash over the boat, a connection is made between this automatic gear and water spray located at the discharge end of the ejector, and supplied with sea water. In order to prevent the "in-wash" of a rolling sea the discharge end of the ejector has been raised well over the highest water line, and a self-sealing sea-gate has been provided, which is also connected with the automatic gear. This inter-connection of different elements that have proven so objectionable on emergency steam ejectors leaves nothing to the fireman or stoker to forget, — this being so very important in marine practice.

On an actual test with a flow meter it was found that a ton of ash with clinkers up to 5 in. in size has been discharged in eight minutes at a total expenditure of 120 lb. of steam, at 200 lb. pressure. The minimum diameter at its throat was  $\frac{1}{2}$  in., and the height of the ejector itself was 22 ft. Based on these figures it is easy to estimate on the total requirements in fresh water which cannot be returned to the condenser during an average voyage. Should an 8000-ton boat consume about 500 tons of coal on a given voyage, producing, at 12 per cent, 60 tons of ash, the total amount of fresh water required and lost would amount to 7200 lb., which is about  $3\frac{1}{2}$  tons. The average vessel of this size will carry about 300 tons or more of fresh water in its tanks, so that the total and definite sacrifice in fresh water will be somewhat over one per cent of the water carried in the tanks. The coal required to evaporate 7200 lb. of water at an evaporation of 8 lb. will be about 900 lb., or approximately half a ton.

The greatest single return for this apparent sacrifice will be the saving of that amount of coal that must be saved by not requiring the ejector pump to operate. The amount of steam required by this pump is usually problematic, and depends upon its size, its

distance from the ejector proper, and its condition of repair. Other elements entering into the steam consumption of this pump are the frequent clogging of the ejector pipe, — during which time the pump often continues to operate unnecessarily — and other possible disorders with both the pump and the ejector. Due to these variables, and the fact that no reliable figures are available as to the actual steam consumption, it is assumed that about two to five per cent of the total coal consumed on a voyage could be saved by replacing the hydraulic ejector with a good steam jet ejector. On this basis in above example, about 10 to 25 tons of coal could be saved out of the total of 500 tons consumed.

Other advantages in favor of a good steam jet ejector are:

- Extreme simplicity of construction, — so very important on board ship,
- Considerable reduction in cost of repair and maintenance,
- Elimination of a cumbersome ash hopper in the crowded stoke-hole;
- Prevention of flooding of stoke-hole,
- Considerable reduction in time and labor required for ash ejection.

It is evident from the foregoing that the application of a steam jet arrangement for ash ejection on board ship is both feasible and advantageous, provided the proper requirements of marine practice are fully met.

The writer wishes to confine his remarks to what the authors refer to as "Air Conveyors" only. While it was admitted that these conveyors have their great merits from a number of view points, it seems that the general impression gained by most of us is that they are anything but economical in their steam consumption. To best offset this assumption, the writer wishes to refer to a number of installations where a considerable reduction of steam consumption was achieved solely by re-arranging the layout of the conveyors. Unfortunately, however, this important matter has been given little consideration in the past, so that there is little wonder that steam jet conveyors became known as a wasteful apparatus in steam.

Steam jet conveyors, — contrary to the so-called vacuum conveyors, — if properly laid out will fully utilize the thermodynamic action of the steam jet, both in the suction and pressure line of the conveyor. Steam leaving the exhaust nozzle of a so-

called vacuum conveyor will always be of higher pressure than it should be in case of a steam jet conveyor, which, of course, proves the respective efficiency of either type.

Years of experience in this particular field have proven to the writer that the average engineer is not expected to know the intricacies of ash handling by the steam jet principle, and that it requires an expert in this line to pass on suggested layouts. To elaborate on this subject would be beyond the limit of this discussion at this time.

In the case of the marine ash ejectors, it was shown that the proper design of the steam nozzles is of extreme importance as a means of reducing considerably the steam required. This applies to stationary practice also. Assuming that a conveyor has been laid out to best advantage, and the steam nozzles have been designed properly, the only important requirement left is the proper design and material of the different fittings. These should be so designed that they will be easily accessible in case of repairs or replacement of their different wear liners and be cast of hard enough iron to resist abrasion successfully.

It remains to those interested in the greater popularity of steam jet ash conveyors to point to the increasing number of satisfactory installations both from the standpoint of low steam consumption, as well as proper design of the layout and different fittings. The growing interest in this type of ash conveyors proves that they are on the right track.

CHARLES E. PROUT. Regarding Par. 15 of the paper, the manufacturers of G & G telescopic hoists have developed methods of handling ashes for the types of buildings for which the authors state no satisfactory means of handling have been found.

The ashes are usually placed in cans and delivered at the point where they are to be raised to grade level; and, as stated, the problem is really that of hoisting the ashes from the boiler room to the street. The block and tackle is out of the question because it is slow and the factor of labor too high.

With this hoist and its supplementary equipment, comprising a complete unit, it is possible for one or two men to take care of the entire work of removing ashes with only a small labor cost. There are four principal models, one of which will meet the particular conditions in such buildings as hotels; schools, hospitals, office buildings and factories, where the ash removal problem is as previously stated. There are two general divisions of conditions.

First: In a hoistway so located that a wagon or railroad car can drive alongside. The depth of the area and the distance of lift are the factors that determine whether electric or hand power should be used.

The normal position of this hoist when not in use is underneath a pair of checkered steel or vault light sidewalk doors about 4 by 4 ft. square. The first step when it is desired to remove ashes is for the operator in the hoistway to turn a crank which raises the hoisting head into working position. This operation automatically includes the gradual opening of the steel doors over the hoistway and when the hoist has reached its extended position the doors are automatically locked open. Gates permanently attached to the leaves of the door, guard the hoistway, preventing the possibility of passersby falling into the pit. One of these gates is a fixed member and the other (having spring hinges) can be opened outward, but cannot be swung inward.

The overhead crane is raised and held in position by a strut and the hoist is ready for work. With this equipment it is customary to use only two men. One man can operate the motor and take care of hooking full cans and unhooking empty cans as they are raised and lowered. The average can filled with ashes weighs about 150 lb., or approximately 3 cu. ft., and can be raised and lowered at a speed of not less than 60 ft. per min. With the use of swing bail cans supplied with the hoist, the man above can empty the ashes directly into the truck without unhooking. The hoisting head swings on ball bearings from a point directly over the hoistway to a convenient position over the truck, so that practically no effort is required to swing the can around. When the ashes have all been removed the overhead crane is lowered and the entire apparatus telescopes below the grade level. Sidewalk doors are automatically closed and locked. The spring guard gates fold below the grade level. The amount of current consumed by this apparatus is surprisingly small, as shown by various tests.

Second: In buildings where conditions are similar, except that it is not possible for a truck to drive close up to the hoistway, a telescopic electric hoist, which has not the overhead crane feature, may be used. The motor in this case is located on the hoisting head and controlled at the grade level. Very recent improvements in this type of hoist include a gravity lowering device so that ash cans (or any load up to 500 lb.) can be raised at a speed of 60 ft. per min., and lowered by gravity under brake control. This gravity

lowering feature saves current and increases the speed in handling large quantities of ashes.

Regular monthly lubrication is really all that is required. This ash-removal equipment is particularly desirable for use in schools, hospitals, and other places where any unusual amount of noise must be eliminated.

For smaller plants these two types of hoists (cellar to truck height and cellar to grade level) may be obtained for hand power operation; but for buildings where the real problem is that of hoisting large quantities from the boiler room to the street, the electrically operated types which have been developed after many years of study and are especially made for handling ashes, are most satisfactory.

While the apparatus used by the Union Electric Light and Power Company, St. Louis, Mo., as described in Par. 16, might have been an improvement over former methods used, the operation described could not have been speedy. For the average plant operator it has been our experience that the service rendered by such equipment would be entirely too slow and otherwise unsatisfactory.

THE AUTHORS are gratified by the very interesting discussion which shows the great interest taken in the subject.

As Mr. Marsh has said, the 8-in. air conveyor is about the maximum size for economy of operation. Above this size, the capacity is greater than that of the man feeding it; and as the steam consumption is directly related to the capacity, there is considerable waste of steam. The highest economy is attained when the capacity is kept down to that of the operator. Similarly, shutting off the steam by means of local controls when ashes are not actually being fed results in enormous reduction in steam consumption.

Mr. Allen's discussion of the difficulties of quenching ashes and of his improvements in sprayers is very welcome. The "efficiency" of ash quenching is very low, as it is impossible to get the water exactly where it is wanted except when the ashes are actually drowned out as in Figs. 16 and 22. Any method which results in getting the water to the hot ashes only will save a large proportion of the cooling water.

While Mr. Funk generally confirms the authors' conclusions, it seems advisable to refer to Par. 90 describing the conveyor illustrated in Fig. 22 where it is pointed out that in some cases "only

a single conveyor is used with auxiliary chutes for use in case of breakdown." Ashpit storage is not practiced with these conveyors. With some forms of continuous conveyor, ashpit storage is desirable in case of breakdown. It is a matter of judicious correlating of the different factors.

Trouble with gas explosions in the storage tanks of air conveyors was experienced with some of the early installations, but this difficulty appears to have been entirely surmounted. When wear occurs in places where there are no wearing backs, it is obvious that they should have been provided, and this is one of the points which are being improved in the development of the air conveyor.

Replying to Mr. Elmer, some powdered coal installations result in the ash being melted to a slag which can be tapped off as in a blast furnace or foundry cupola, or allowed to cool and be broken out with the expenditure of much labor. The use of the water screen at Milwaukee results in causing the ash to be deposited in a fine powder which is easily handled with an air conveyor. Reference should also be made to the reply to Mr. Beaumont.

Mr. Moulthrop well summarizes the salient problems of the modern power station as those of water, coal and ashes; and points out that the final disposal is one of the most serious features of the ash problem. But it is not convenient to discuss ash disposal in a paper of this kind, because that is a matter which is governed by the environment of the plant and which must usually be determined as one of the primary conditions of operation. The mechanical features of handling the ashes must then be decided upon to suit this condition, and they may even have to be sufficiently flexible to meet a change to a different condition of disposal at some future time. The development of mechanical contrivances for handling ashes, may, however, have a distinct bearing in widening the field for final disposal as in the case of the Springfield and Windsor plants of the West Penn Power Co.

The remarks of Mr. Maynz confirms the authors' views on the quality of experience and judgment which should be brought to bear in deciding on an ash-handling system. Headroom is expensive, and the usual engineering compromise must be made between first cost and cost of operation; but "in designing new plants ample headroom should always be provided," as stated in Par. 32.

Mr. Libby's experience also confirms these views and shows the necessity of full investigation of the problem before proceeding with the design of the apparatus.

Mr. Tenney clearly shows how each individual plant must be separately considered and that method adopted which will most suitably meet the particular requirements. He also shows how these requirements have been met by the adoption of different methods in different plants.

The freezing of the ash bunker gates in winter and the method of thawing them is of particular interest. The wet ash in the hopper may also freeze in some cases, and have to be thawed out. Climatic conditions must not be neglected in ash handling as these may have considerable bearing on the methods available.

Mr. Rankin Eastin's installation is a very successful example of water sluicing, and is the more creditable as he originated the scheme without knowing of any similar system elsewhere and therefore without the guidance of the experience of others.

Mr. Prout's description of the telescopic ash hoist which has been developed for hotels, office buildings and other cases where ashes have to be lifted from basement boiler rooms to the street level is of considerable interest and may be compared with the earlier attempts such as that described in Par. 16. The low cost of operation is worthy of attention.

Mr. Beaumont's description of an ash car and skip hoist installation is a valuable addition to the discussion. But in championing the skip hoist, Mr. Beaumont should not feel disappointed that the paper was not more completely devoted to it as the object was to describe the various systems in use and not one particular method. The authors are in accord with him as to the simplicity and flexibility of the ash car and skip-hoist as well as to its capacity for extension, as is obvious from the paper.

As to the size or absence of a hopper with continuous conveyors, the reply to Mr. Funk applies equally here.

That steel-plate hoppers have been longer in service than those of cast-iron plates does not mean that experience with these materials is limited to the relative duration of their use in this manner. The materials have been used in comparison in situations where the conditions are quite similar to those of this service, and the greater durability of cast iron over wrought iron and steel is very well known indeed. Of course, it is obvious that with adequate protection, the steel plates will not be corroded; but experience with protective coats generally makes it wise to choose materials which will suffer the least if the protection fails.

The passage of large clinkers through the ash-handling system

to final disposal is not always either convenient or desirable. In some instances a conveying system which will not handle large clinkers is preferable owing to its other advantages, and large clinkers must either be broken by hand or by mechanical crushers. Also, there are cases where ashes can be utilized if small, but not when containing large clinkers, and this may interfere with ash disposal.

The relative movement between the ashes and the conduit in air conveyors has been amply considered in the paper. The advantage of having no moving parts lies largely in the greater amount of wear which stationary parts will usually stand before needing renewal and in the ease with which erection and renewals are handled. Moving parts require much more mechanical skill and time for their proper fitting to enable them to work properly without undue friction and breakage, than stationary parts.

With reference to the Lakeside plant of the Milwaukee Electric Railway and Light Co., Mr. Beaumont has inadvertently appeared to discredit modern powdered coal burning through lack of information. The skip hoist he mentions has nothing to do with the subject of ash handling. As Mr. John Anderson has just written us, "it was put in to act as an elevator to the basement for handling material that an air conveyor system was never designed to handle. This includes castings, brick for furnace repairs, and any other material that is used in the basement of a boiler room for the maintenance and operation of the equipment in such basement." As is stated in the paper, all the ash at Lakeside is handled by air conveyors.

Mr. Bell's comments are very valuable and generally accentuate the authors' views as expressed in the paper. His detailed description and comments on the Springdale and Windsor plants should be very highly appreciated, and reference to Fig. 16 may well be made in studying his discussion.

One or two of Mr. Bell's remarks call for comment as being evidently based on misunderstanding. From Par. 38, it will be seen that the authors condemn the admission of air to the ashpit which results in combustion therein, just as strongly as he does. Also, reference to Par. 27, will show that the authors wrote that in addition to other things "allowance must be made for unburned coal coming in with the ash." This allowance should not be less than 25 per cent, as Mr. Bell says.

Mr. Eugene Hahn makes a strong plea for the use of the air

conveyor on shipboard. As he well says, the disadvantage of the loss of water must be weighed against the obvious advantages. But the air conveyor in good condition should not be compared with the water ejector with its pump out of repair. The two kinds of apparatus should be compared when in a similar and reasonable condition. As pointed out in the paper, the very simplicity of the air conveyor sometimes leads to its neglect.

While the test mentioned showed only 120 pounds of steam per ton of ash, it is generally found in land practice that the steam consumption under regular working conditions averages considerably more than this. The analysis of a definite case, however, would not be invalidated if based on the usual figures obtained from stationary plants.

The discussion of marine practice was not undertaken at any great length in the paper. The subject is one well worthy of more deep study and Mr. Hahn's contentions should not be lightly dismissed.

Mr. Hahn's remarks on the thermodynamic action of the steam-jet in the two types of air conveyor in general use are open to contention. The steam may be expanded to a lower pressure in a vacuum conveyor than in the so-called steam-jet conveyor, but whether this is done in actual practice depends upon the design of the nozzle in each case and not upon the conveyor system.

The authors wish to express their full appreciation of the great trouble taken by those who have contributed to the discussion and so worthily amplified what was written in the original paper.