

No. 1847

CENTRIFUGAL CASTING

BY LEON CAMMEN,¹ NEW YORK, N. Y.

Non-Member

The paper describes the process of centrifugal casting of hollow metal objects. The author first takes up the field of centrifugal casting and the history of the development of the art, which he follows by a discussion of the mechanics of the problem and a description of the operation of the casting machine. He then takes up the thermal conditions in the mold and the field of application of hot-mold centrifugal casting, and closes with a discussion of the manufacture of plates by the centrifugal casting process.

In appendices to the paper are given a bibliography of the subject, a list of patents, some of the mathematics covering the cases of casting about a vertical and about a horizontal axis, and the forces acting on the liquid metal in the direction of the axis of the mold, a discussion of temperature control in the casting and in the mold, and an analysis of the stresses in the mold.

1 The art of centrifugal casting of hollow metal objects is quite old and has been practiced on a commercial scale since the beginning of the last century. The earliest English patent (Eckert) dates as far back as 1809, and the earliest American patent to Lovegrove was issued in 1848. At about the same time Andrew Shanks, in London, England, began to make cast-iron pipe 12 ft. long and 3 in. in diameter by pouring molten metal into a spinning wrought-iron mold. His process was described in America in the *Scientific American* of December 1, 1849, and it is of interest to note that in its basic features of design the Shanks machine does not differ in any way from the great majority of machines working with a cold mold at the present day.

2 Attempts were made at an early date to apply centrifugal casting to ingot making with the view to improving the quality of the metal and, for example, M. Tresca, in a paper before the Institution of Mechanical Engineers,² states that the most remarkable

¹ Associate Editor, *Mechanical Engineering*.

² *Proceedings*, 1867; pp. 149-150.

instance that he had met with of freedom from air bubbles was in the case of a bessemer rail manufactured at the Imphy Iron Works near Nevers in the Department of Nièvre; and he had ascertained that the method adopted at these works was to pour the molten metal into a revolving vessel driven at a considerable speed so as to clear the steel of air by rapid rotation. This method proved very effective in practice in freeing the steel from the minute air bubbles which it contained on leaving the converting vessel or the melting pot.

3 A survey of the literature (see Appendix No. 1) and of the numerous patents issued on centrifugal casting in this country (Appendix No. 2) and in Europe would indicate that practically all the essential features were covered by patents issued prior to the beginning of the twentieth century, with the exception, however, of those dealing with the temperature control of the metal, which is a new feature. It would appear, therefore, that with the exception of minor details and one or two features in special casting processes there is no reason why any good engineer could not design and operate a successful casting machine with a non-heated or non-cooled mold without running into legal complications. At the same time, it might be well to realize that the very fact that the basic features of the general process are already free makes those who have developed some of the few minor features particularly anxious to protect their patent rights in them. Because of this a general familiarity with the patent situation is desirable to avoid involuntary infringement by using some minor detail such as, for instance, a particular type of pouring spout that has been covered by a patent. It is to assist in this that Appendix No. 2 has been prepared, giving as far as the author is aware, a complete list of all patents on centrifugal casting issued since 1848 by the U. S. Patent Office and prepared after a careful investigation of the entire field. (See also Appendix No. 1, Bibliography).

MECHANICS OF CENTRIFUGAL CASTING

4 In the first place, a clear distinction should be made between casting about the horizontal and about the vertical axis and also the intermediate case of an inclined axis. In casting about a horizontal axis the metal is distributed symmetrically about the axis of rotation, and if the axis of rotation coincides with the axis of the spinning unit, a tube of uniform thickness is produced for the entire length of the mold. If a vertical axis is used it is obvious

that the external wall of the casting follows the shape of the mold while the interior of the casting forms a paraboloid of revolution, the elements of which depend on various factors given in Appendix No. 3. In casting with the inclined axis the same general principles apply, with the further complication that the elements of the inside paraboloid of revolution are also affected by the angle of inclination of the axis to the true horizontal.

5 The usual way of casting is by introducing molten metal into the spinning mold. Where the chilling of the metal is extremely rapid, as, for example, in casting cast-iron pipe against a water-cooled chilled mold, it is imperative to use a movable spout, the latter sliding at a certain predetermined rate so that by the time the nozzle discharging the metal comes out of the mold the entire pipe is completed. This is the process employed by DeLavaud. Other manufacturers working with the cold mold have attempted to secure the same results by what is known as a trough spout, which is really a trough into which the entire metal of the casting is poured at a rapid rate. The trough is then tipped and discharges the metal suddenly, the metal falling on to the walls of the mold at such a rapid rate that a pipe forms before the metal has had time to chill. Hitherto this process has met with only indifferent success.

6 A better result has been achieved on comparatively short castings, however, by the use of a ledge spout, the spout ending in a flat ledge along which the metal can flow the entire length of the casting. Finally, where a hot mold is used an ordinary short spout is employed, the metal distributing itself throughout the mold longitudinally under one of the components of centrifugal pressure or pressure produced by centrifugal action (Appendix No. 3). This arrangement cannot be used with the cold mold for reasons explained in the Appendix.

7 In centrifugal casting the distinction should be clearly made between jobbing work and mass production. For the former, clay molds in iron cases have been used practically exclusively, as it would not pay to make a permanent mold for only a few castings. When it comes, however, to production on a tonnage basis, such as tubing or pipe, a permanent mold is practically the only feasible way of doing it. Crucible graphite or zirconia tubes have been successfully used for castings not in excess of 3 ft. in length, but when it comes to longer ones, metal molds are to be preferred. Fairly successful results have been obtained with chrome-nickel

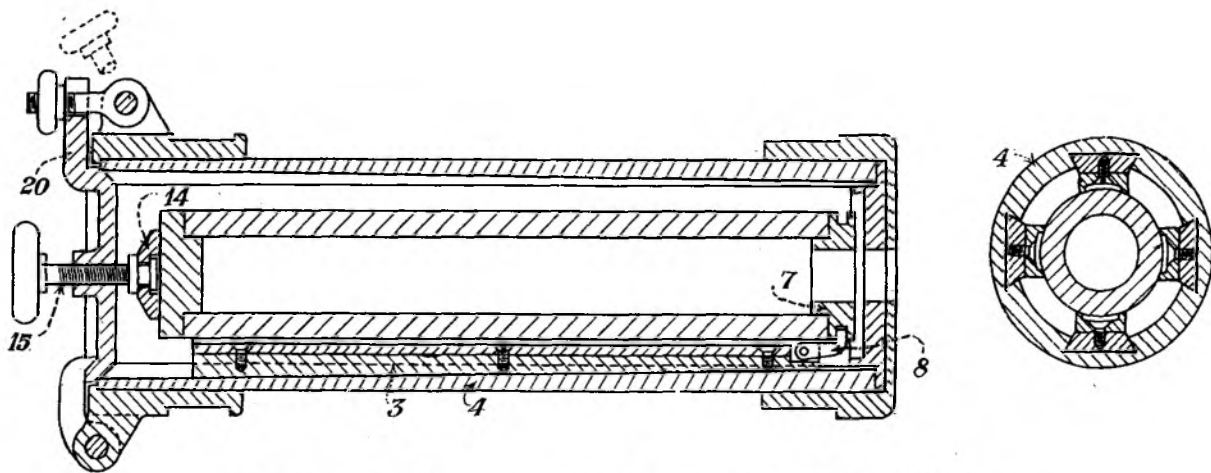

FIG. 1 SPINNING MACHINE FOR USE WITH REMOVABLE MOLDS, HEAVY TYPE

alloys, though it is not expected that this will be the material finally adopted, as enough work has been done already on the production of cast tungsten to make it certain that a mold of this still rather mysterious material will be available within a comparatively short time.

8 There are several ways of supporting the mold in the spinning bench, depending on whether the mold is a permanent fixture or removable and also depending on the size of the mold. Where the mold is a permanent fixture as it is today wherever a cold mold is used, any kind of bearings, providing they are substantial enough, may be used. With removable molds the conditions are somewhat different, especially where the mold is heated to a high temperature. (It will be shown later that the temperature of the mold at the time of pouring the metal may be as high as 2000 deg. fahr.—see also Appendix No. 4.) Where extremely hot molds

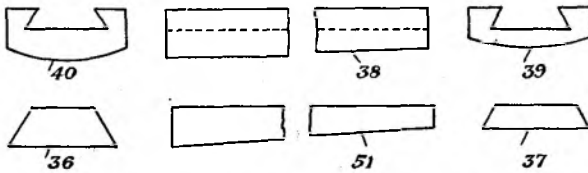

FIG. 2 GIBS AND BEDS OF THE SPINNING MACHINE SHOWN IN FIG. 1

have to be used, the arrangement must be such that the stresses on the mold can be reduced to a minimum, and that the mold can be rapidly and easily inserted into the machine and extracted therefrom. The matter of stresses is of very great importance in view of the fact that, especially in large machines, the bursting stresses due to the action of centrifugal force are of such magnitude as to require the most serious consideration. (Appendix No. 5).

9 The spinning bench for such removable molds works on a comparatively simple principle, the mold being held in a barrel rotating on rollers. The barrel construction shown in Fig. 1 is particularly suitable for use with hot molds. Here the barrel consists of a steel shell, 4, which may be an extra heavy steel pipe, but in sizes above 12 in. has to be made as a special casting. At four to six places symmetrically spaced along the inner circumference of the shell, steel strips tapered at 39 and 40, Fig. 2, and with face machined to the same radius as that of

the internal surface of the shell, are screwed on or riveted on. The strips are provided with truncated slots as shown in the figure, and in these slots move the keys or gibs 51, the cross-section of which is shown by 37 and 36, which indicates that the face 36-37 is of the same width from one end of the gib to the other, but the height of the trunk varies.

10 It is obvious that as long as the four gibs move through the same distance longitudinally in their tapered beds, the faces of the gibs will remain parallel to each other but the enclosed cylinder tangent to those faces will vary in diameter with the position of the gibs.

11 The operation of the machine is therefore as follows: The head, 20, is opened and the gibs pulled out a little way until the tangent cylinder is, say, a quarter of an inch larger than the external size of the mold. The mold is then inserted, preferably without touching the gibs, until it comes to bear against the abutment ring, 7, to which all the gibs are attached, (for example by hooks, 8). As the mold presses against the abutment the latter recedes and carries with it the gibs, which by moving in their tapered beds gradually contract until they come to grip the mold, and they may be made to grip it as hard as desired simply by exerting sufficient pressure on the abutment, 7, which may be done through the block, 14, by the screw, 15.

12 The important advantage of this construction lies in the fact that, first, the mold automatically finds its own center, and, second, that it is supported all along its length, a matter of great importance when we come to deal with the bursting stresses in the mold. (Compare Appendix No. 5.) Whether a solid or a split mold should be used is a matter determined primarily by the shrinkage condition of the metal of the castings and the metal of the molds. Where the shrinkage conditions are such that the casting comes out of the mold easily, that is, where it contracts quicker than the mold, a solid mold may be used, but where the shrinkage conditions do not guarantee easy extraction of the casting, or where the shrinkage conditions are non-uniform, the use of a split mold has been found advisable. Such molds are usually split longitudinally and the question of the best method for holding the two parts together is far less simple than it appears at first sight. There are numerous patents showing the two split parts of the mold held together by bolts. In actual construction, however, the use of bolts for this purpose is entirely unsuitable, as may be shown by simple calculations.

13 To meet this condition the mold shown in Fig. 3 has been developed. This mold has side lugs machined in such a manner that when the two parts are put together a tapered structure, such as 6, is obtained, and dovetail pieces, 5, are provided to engage with the taper 6. It is obvious that when the dovetail piece, 5, is driven hard over the lug taper, 6, it will hold it tight. Furthermore, both the lugs and the dovetails can be made within reason practically as heavy as desired, so that a good factor of safety can be provided to take care of bursting stresses in the mold. To close or open the mold, it is only necessary to apply pressure to the dovetail piece or give a light blow, and by means of a simple jig the blow or pressure can be applied to all the dovetail pieces on the mold at once.

14 Such a construction diagrammatically is shown in Fig. 3. It is obvious, however, that the presence of the lugs makes the machining of the mold to a true cylinder expensive, if not impossible. Because of this, instead of machining the mold to a cylinder, a number, such as four, of flat faces are planed on the mold, the location of the faces being such that they will be distributed symmetrically around the longitudinal axis of the mold and that they will be tangent to a circle described with the point on the axis of the mold as a center. Such an arrangement is comparatively easy to carry out and it gives an excellent support for the mold, besides providing a structure a good dynamic-balance properties.

15 As regards the foundations and bearings for centrifugal-casting machines no special design need be described here, but it should be most clearly and strongly emphasized that both the bearings and the foundations should be of very generous proportions and most substantial design. The machine in centrifugal casting is subject to quite violent strains and unless it is properly built it is apt to get into vibrations which sooner or later may have a dangerous effect. The writer knows of a case in an American plant where a centrifugal-casting machine located in a ditch and built with insufficient ruggedness actually jumped out of the ditch during operation, endangering the lives of those around it. With steel and concrete amply available there is no excuse for such practices.

16 Up to about two years ago very little work, as far as the writer knows, had been done successfully on the problem of casting centrifugally comparatively thin sections, say, under $\frac{3}{8}$ in., in such metals as steels or monel and in lengths beyond 3 ft. On the other

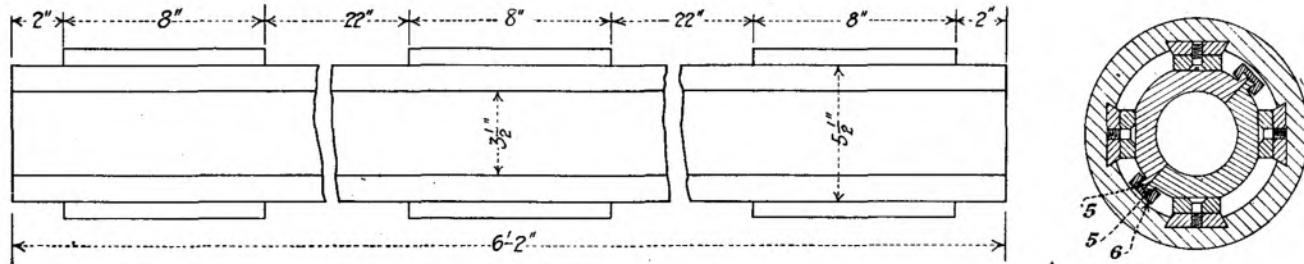

FIG. 3 VARIATION OF FIG. 1, WITH SPLIT MOLD HELD TOGETHER BY TAPERS AND DOVETAILS

hand, large castings in brass, bronze, cast iron and even steel have been made with considerable success. The reason for this lies in the failure to understand the thermal conditions in the mold and the process underlying the freezing of the metal.

17 There is a basic difference between castings in a stationary mold and in a spinning mold. In making castings in the former, whether it be a simple ingot or a complicated casting from a pattern, the foundryman has means to provide for the escape of gas from the metal and for taking care of the cavities produced by contraction in cooling. In a casting from a pattern, sink heads are provided, while in an ingot casting the

top of the ingot acts as a sink head, in addition to which special methods such as "dozzling" may be used to keep the top of the ingot hot as long as possible, and increase the efficiency of the ingot top in performing the functions of the sink head in molds. In both cases the foundryman is prepared to discard as defective a certain part of the casting (the ingot head, risers, sink heads) and his skill lies partly in reducing the quantity of discard as far as possible and especially in directing the process so as to restrict the presence of defective metal to the parts which he is prepared to discard.

18 In centrifugal casting, there is no riser or

anything corresponding to the ingot top, and the cooling proceeds essentially at a uniform rate all along the length of the tubular shape. It is obvious, especially in tubes of small diameter and considerable length, such as 6 in. outside diameter and 16 ft. long, that the loss of heat inward must be extremely small, because the entire inner air cylinder is surrounded by metal at approximately the same temperature. Heat is therefore lost mainly outward to the mold and through it to the air. As a result of this, the part of the casting in immediate contact with the mold chills first. The problems with which the "centrifugal" foundryman has to deal are essentially the same as those which confront the man pouring into stationary molds, and these are, first, to get rid of the occluded gases, and, second, to take care of contraction cavities. As regards occluded gases and slags, it would appear at first sight, especially to those familiar with such centrifugal processes as cream separation, that they would be eliminated automatically; pure metal, being heavier than either slag or metal containing gases, should be thrown to the outside, against the wall of the mold, while all impurities should go to the inner wall. This does actually happen, provided one condition is satisfied, and that is that sufficient time is available; and it should be remembered in this connection that this separation takes place at a fairly slow rate because of the great viscosity of molten steel.

19 The second problem is that of cavities formed in the casting as a result of contraction in cooling. As stated above, the part of the casting in immediate contact with the mold chills first. In doing so, it contracts, and if left to itself, might easily form contraction cavities and thin spots. If, however, the rest of the metal is still in a liquid state, it is projected, with a pressure at the rate of, say, 100 lb. per lb. of metal, against the chilled layer, and fills all possible cavities with an efficiency many times greater than can be obtained with sink heads in stationary casting. (To obtain the same results in a stationary mold, it would have been necessary to put into the sink head 99 lb. of metal for every pound of metal in the actual casting, a proposition that is not likely to appeal to a sane foundryman.) This again presupposes, however, that the cooling proceeds at a fairly slow rate, and enough time is available for each succeeding layer to take care of chill conditions in the preceding layer. In cold-mold centrifugal casting, which means with a mold warmed only enough to take off the chill, say 300 to

400 deg. fahr., temperature conditions do not favor slow cooling, which is one of the reasons of the many past failures to produce thin-walled steel tubing by centrifugal casting. On the other hand, very excellent steel tubes (both plain carbon and nickel alloy) have been produced with diameters ranging from 10 in. up, and wall thicknesses up to $3\frac{1}{2}$ in. In the latter case there is so much metal in comparison with the area in contact with the mold that enough time is available to produce a good segregation of impurities inward before the inner wall freezes.

20 It would appear, therefore, that the secret of producing centrifugally thin metal castings (under $\frac{1}{2}$ in.) lies in establishing conditions under which the cooling of the molten metal will proceed at a fairly slow rate. This applies, of course, only to such metals as steels and monel, but not to bronze, which is governed by different conditions. In the Cammen process this has been accomplished by preheating the mold to a temperature close to the melting point of the metal itself, which may vary from, say, 1600 to 2000 deg. fahr. for steel and monel-metal castings (Cp. Appendix No. 4). Under these conditions a $\frac{3}{16}$ -in. wall takes about 45 to 60 sec. to harden entirely, which is sufficient to produce clean metal. Casting in such extremely hot molds is a rather novel procedure and at first one might anticipate trouble due to oxidation and warping of the molds and the difficulty of handling big molds conveniently. As a matter of fact, however, with proper equipment it offers comparatively few difficulties. The question of oxidation of molds is taken care of by using proper alloys, such as alloys of a nickel-chrome base or cast tungsten (the latter is not yet being done on a commercial scale). The question of warping is partly taken care of by the same use of proper alloys, but mainly by the use of extremely substantial molds and proper facilities for handling them between the casting machine, the transfer table and the furnace. In all this handling, the molds have to be properly supported throughout the entire length, either by carrying them on a very heavy "horn" extending from one end of the mold to the other, or in a cradle supporting the mold throughout its length.

21 The method of operation is as follows: The mold with its casting inside, both at a temperature well above white heat, are rapidly pulled out from the casting machine and carried over to what is known as a transfer table, where the casting is pushed out of the mold by a hydraulic plunger. While the casting is going to

the proper rolls or benches, the mold itself is coated inside by a protective layer and carried over to a reheating furnace. The furnaces used in this connection do not differ essentially from the billet-heating furnaces in tube mills. The mold coating is intended to protect the metal of the mold from coming into direct contact with the molten metal of the casting and need not be more than, say, $\frac{1}{8}$ to $\frac{1}{32}$ in. thick. It consists of some refractory material like alumina, zirconia, kaolin, electrically calcined magnesia, or the like. Either pitch with some addition of solvent naphtha or clay may be used as a binder, the former being preferable as it contains no water. The coating may be applied either by a swab or through a compressed-air gun.

22 The transfer table referred to above cannot be described here owing to lack of space. It is a somewhat cumbersome piece of apparatus which may weigh from 2 to 10 tons, depending on the sizes of the castings handled, and is a practically self-contained unit operated from a cab by pulling a series of levers one after another.

FIELD OF APPLICATION OF HOT-MOLD CENTRIFUGAL CASTING

23 The particular feature that determines the field of application of hot mold centrifugal casting is the ability to produce cast shapes of comparatively thin metal (down to $\frac{1}{8}$ of an inch) in great length, with our present knowledge of the art up to 20 ft. One of the first applications that comes to mind is in the production of seamless tubing.

24 Hitherto the principal tonnage of seamless tubing has been made by the Mannesmann piercing process and its variations. Essentially this process consists in imparting such a twisting motion to a steel billet as to break down its central fibers. This motion is set up by means of obliquely placed rolls or disks. There are several objections to this process. In the first place, while it does pierce high-grade mild steel or Muntz-metal billets, it stresses the central part of the billet far beyond its elastic limit. While apparently this does not affect very seriously the tensile strength of the finished product after it has been cold-drawn or hot-rolled, there is good reason to believe that it impairs the resistance of the metal to corrosion, the latter, as we know now, being particularly active in the case of metals stressed up to or beyond the elastic limit. Furthermore, the Mannesmann process is not at all applicable to

metals which are either extremely tough or very brittle. Thus, all attempts to produce commercially by the Mannesmann process, hollow billets of either monel metal or Admiralty brass have so far failed. Not only that, but the Mannesmann process, by its very character, is limited to the production of comparatively small sizes, not in excess of 6 in. in diameter; while experimentally larger sizes have been made, the 6-in. limit has been pretty well established for standard commercial grades. It is obvious that as we go up in sizes, the piercing mills used in this process increase in cost with great rapidity, and as the cost of even a small Mannesmann mill easily runs into six figures, the cost of the big ones becomes prohibitive after passing a certain limit, which is around 6 in.

25 At the same time there is a demand for larger sizes of tubing of greater strength than a single-welded joint can give and this is where the most obvious field of hot-mold centrifugal casting appears. With this process, tubing in extra heavy and double extra heavy thicknesses can be easily produced in sizes up to 24 in. in diameter at a cost per ton that can compete with plain welded tubing and it is considerably lower than that of double-welded tubing such as is used for hydroelectric installations.

26 The next field of application in connection with steel tubing is in standard sizes from 6 to 14 in. up, where welded tubing is now used exclusively. Such pipe can be produced in two ways: First, by casting a hollow billet of wall thickness two to three times that of the finished pipe, and either cold-drawing or hot-rolling it to size. In such a case the billets cast would be roughly 8 to 10 ft. long so as to have say, 22 ft. in the finished pipe, barring cropped ends. The other method is to cast the pipe direct with only a slight excess of wall thickness and then to give it one pass between straightening rolls over a ball, so as to reduce the diameter and wall thickness to exact size with standard tolerances, and give the exterior and interior walls a finished appearance. From data now available it would appear that the final cost of both kinds is approximately the same and is well within the range at which centrifugally cast-steel pipe can compete in price with welded pipe.

27 It is only natural that this should be so. In pipe manufactured by the standard processes, steel is cast in ingots, which, after cropping and several thermal and mechanical operations, are rolled into skelp. The skelp goes to a pipe mill, is heated to a red heat and rolled to bevel edges, after which it is sent through the bending rolls. It is next reheated to welding heats and in succes-

sion passed through welding rolls, sizing rolls and finally straightening rolls. Each of these operations is done, of course, by appropriate machinery developed to a remarkably high state of perfection, but nevertheless each operation adds its mite to the final cost of the article, and this mite is not inconsiderable in view of the immense tonnage produced. In centrifugal casting the metal is poured into the mold which corresponds to casting the ingot, and the casting is then ready to go to the final rolls, which can be done without reheating. There is at least 50 per cent less handling of material in centrifugal casting than there is in making pipe by welding, and such a difference cannot help being reflected in costs.

28 In this connection it might be well to mention one of the psychological factors with which centrifugal casting is concerned, and that is, the not unfounded distrust of users of metal products toward castings, especially those in thin sections. Such castings cannot be produced commercially in a stationary mold, and steel castings in a stationary mold as made today generally are of such physical properties as to be usable only where they are not subject to complicated stresses and where an extremely high factor of safety can be provided. Wherever the stresses are high and especially uncertain and the factor of safety is not more than ample, no engineer today will use a casting but will insist on either a forging or a piece machined or hot-rolled.

29 This not unfounded distrust of castings is due to the fact that in either the sand casting or chill casting the temperature conditions in the metal are uncontrollable, with the result that one part of the metal may be entirely different in its physical properties, such as hardness and crystalline structure, from the other, and there is no guarantee that two castings made under apparently the same conditions will be entirely alike. There is too much individuality in products cast in stationary molds to make them suitable for engineering requirements where a failure would be disastrous and where only moderate factors of safety may be employed. The situation is, however, entirely different with centrifugal castings, because there ample facilities are available, especially in hot-mold casting, to control the rate of cooling of the metal, and the nature of the process is such as to tend to give a uniform product, provided, of course, the process is carried out properly. From this point of view, one cannot help agreeing with an editorial in the *Iron Age* (Feb. 9, 1922), which states that "the successful operation of centrifugal casting processes insures a product, no mat-

ter of what composition, which is of a high grade. It is a realization of quality production in quantity, for rapid output is a marked characteristic. There is also the advantage of the elimination of sand and dirt. The condition of casting and cooling tends to produce a dense casting and one whose microstructure is different from the sand-cast products. Centrifugal force is substituted for sink heads as an insurance against unsoundness." This brief analysis in the *Iron Age* states strikingly the difference between sand castings and centrifugal castings, and explains the reason why centrifugal castings may be used on a par with forged or hot- and cold-worked metal where sand castings would be too hazardous.

30 But the field of application of centrifugal casting, especially of the hot-mold type, does not stop with plain carbon steels. There are a number of alloy steels which it would be very desirable to have in tube form, such as stainless steel, high-speed tool steel, chrome-nickel-vanadium steel and the various "near-steels" which are iron alloys with a predominance of materials other than iron, such as heat-resisting alloys. Practically none of these materials will stand for piercing by the Mannesmann process, but cast with great ease into tubular shapes. In fact, even Hadfield manganese steel has been found to make, by centrifugal casting, excellent tubing, although it is very doubtful if it has any commercial application outside of some very limited specialties.

PLATE MANUFACTURE

31 Centrifugal casting is peculiarly applicable to the manufacture of plates. Andrew Shanks, the British inventor of the middle of the 19th century, to whose pioneering work in the manufacture of cast-iron pipe reference has been made above, was also the earliest manufacturer of plate. His process was to cast a thin-walled pipe, cut it, and then by careful annealing and hammering, flatten it out. The process was kept secret and was successful commercially until rolled steel sheet was put on the market.

32 The use of a hot mold makes it possible, however, to secure comparatively thin-walled castings in large sizes. A process has been worked out, though not yet applied on a commercial scale, in which a cylindrical casting is made in such a manner that a longitudinal split of about half an inch wide is produced. The split cylinder as it comes from the mold is sent first through a flattening jig where it is flattened out on its own heat, and then to rolls, of which there are at least two, one for sizing and the other for finishing. Under

certain conditions more than one sizing roll may be required. The casting has to be cast oversize, the wall thickness being from 10 to 15 per cent greater than that of the finished plate. Thus, for example, one-quarter-inch plate would be cast in sizes 240 in. long, 20 in. in diameter and 0.265 wall thickness. It is expected that it can be brought down to a quarter of an inch in one pass in the sizing rolls and that no reheating would be necessary.

33 This process is today only in its initial stages of development. It is attractive, however, as it does away with the ingot-casting work, soaking pits, blooming mill and a great share of the rolling equipment, permitting a conversion from molten metal to finished plate estimated at about \$4.00 per ton.

34 Not only that, but it also makes quite attractive the manufacture of alloy-steel plates, in particular, of such material as acid-resisting steels for use in chemical tanks and the like. These steels are very difficult to roll. The final product could stand the cost of the two or three passes necessary in centrifugal casting of plates, but not the many operations of the conventional methods of plate manufacture, the main item of expense being not the actual rolling but the complicated heat treatment absolutely imperative between the rolling operations. In fact, it would not be surprising if with prices of alloy-steel plates brought within reason, they would be used far more extensively than one would expect to find from present indications.

35 The casting of gears by centrifugal methods, in particular worm and herringbone gears, has been achieved with great success both in England and in America, especially in this country. As far as the writer is aware, however, all such gears have been cast in non-ferrous metals and not in steel.

36 There is one more field of application of centrifugal casting, especially the hot-mold type, comparatively small today, but which may become of material interest shortly, and that is the production of cylinders requiring extremely high strength. When the oxygen industry first called for cylinders that would safely withstand 2000 lb. pressure to the square inch, it looked like a big problem, but it was solved by the progress in the cupping process. When, however, the Haber synthetic ammonia process demanded great pressures combined with considerable temperatures, special expensive tools had at first to be provided for machining the cylinders required from solid stock. The Claude ammonia process goes to temperatures and pressures far exceeding those of

Haber, and the experiments of Professor Bridgman of Harvard University and others point to the likelihood that before many years are past pressures of the range of 100,000, 200,000 and possibly even more pounds to the square inch will be used commercially. At pressures between those used by Haber and Claude and those used by Professor Bridgman for containers of commercial size, carbon steels are but little suitable and the vessels required will have to be made from alloy steels.

37 This may be done in two ways, either directly by centrifugal casting on a vertical axis which would give a vessel with closed bottom, or by the cupping process from alloy-steel plates, which, in their turn, would be made by centrifugal casting as described above. In this connection it may be of interest to mention that a high measure of success was achieved during the war by the Bethlehem Steel Company at Bethlehem, Pa., in casting air flasks for torpedoes centrifugally in a machine running on a vertical axis.

38 No attempt has been made in the above discussion of the field of application of centrifugal casting to present anything like an exhaustive list. Instances have been merely cited to show the enormous field in which this process is or may be employed.

39 The same applies largely to the description of the mechanics of the process, where likewise no attempt has been made to show the historical development of machinery for centrifugal casting or to give details of the actual apparatus. The apparatus has been shown mainly in order to give an idea of the kind of machinery that has to be used.

40 In connection with the mechanics of centrifugal processes it seems appropriate to remark at the close of the paper so as to give it the greatest emphasis possible, that the machinery itself is and should be comparatively simple, for the process when properly worked out is the acme of simplicity. It should be, however, clearly understood that in centrifugal casting we are dealing with large rotating masses and with metal subjected in its molten state to the effect of great force.

41 Furthermore, the distribution of the metal in the mold is effected primarily not by rigid material visibly distributed as in stationary casting, but by the action of invisible forces which do not come into operation until the moment when the metal is delivered to the mold.

42 Because of all this, and notwithstanding the great sim-

plicity of the machinery and methods of centrifugal casting, it should be clearly remembered that even the slightest imperfection in the design or operation will immediately show up in the casting.

43 Centrifugal casting is a process which is peculiarly impossible to be worked either by slipshod methods or on a shoestring, i.e., skimping on the quality of materials and on factors of safety in the design of machinery.

44 There is an old saying current among molders to the effect that a lie in sand will be shown up in the metal. The same applies with still greater force to centrifugal casting. The slightest mistake in the layout of the machinery or use of poor materials in the machine, its bearings and foundations, will produce an uneven casting, result in excessively rapid wear of the molds, and at times may even cause disastrous accidents with danger to life. At the same time, with good engineering and the use of first-class materials, centrifugal casting may be carried on entirely by semi-skilled labor and still give products of unsurpassed excellence.

APPENDIX No. 1

BIBLIOGRAPHY

- 45 The articles enumerated below contain references to previous publications on centrifugal casting: These, as a rule, have not been included.
- 1 Radial Stresses Due to Centrifugal Force in Revolving Bodies, A. M. Levin. *American Machinist*, vol. 27, no. 43, Oct. 20, 1904, pp. 1389-1393, 6 figs.
 - 2 British Adopt Centrifugal Casting, Gwilym Williams. *Foundry*, vol. 48, no. 6, Mar. 15, 1920, pp. 213-218, 15 figs.
 - 3 Die Zentrifugalkräfte und ihre Anwendung in der kosmischen und technischen Mechanik, Prof. Dr. Holzmüller. *Zeitschrift des Vereines, deutscher Ingenieure*, vol. 47, nos. 45 and 47, Nov. 7 and 21, 1903, pp. 1633-1638 and 1706-1710, 19 figs.
 - 4 Fluid Compressed Seamless Tubes, L. J. Krom. *The Metal Industry*, New Series, vol. 12, no. 4, Apr. 1914, pp. 145, 2 figs.
 - 5 Permanent Molds and Centrifugal Castings, J. E. Hurst. *Brass World*, vol. 16, no. 1, Jan. 1920, pp. 11-13.
 - 6 A. E. Fay, Centrifugal Casting, *Iron Age*, February 28, 1901.
 - 7 Ueber Zentrifugalguss, Ernst Lewicki, *Zeitschrift des Vereines deutscher Ingenieure*, vol. 42, no. 26, June 25, 1898, pp. 719-724.
 - 8 Hume Centrifugally Made Concrete Pipe, *The South African Journal of Industries*, vol. 4, no. 3, March-April, 1921, pp. 224-235.

- 9 Non-Ferrous Casting in Spinning Molds, Louis J. Josten (description of the methods used by Geo. Clark Metal Goods Co., Detroit, Mich., in casting copper shell bands), *Iron Age*, vol. 107, no. 20, May 19, 1921. pp. 1289-1292.
- 10 Tests of Centrifugally Cast Steel, Dr. Geo. K. Burgess, *Transactions of the American Society for Steel Treating*, vol. 1, no. 7, April, 1921, pp. 370-382 (published also as a Technical Paper of the Bureau of Standards, and abstracted in *Iron Age*, vol. 107, no. 12, March 24, 1921, pp. 764-766; cp. editorial in same issue, p. 789).
- 11 Centrifugally Cast Iron Pipe, Prof. Peter Gillespie (description of the DeLavaud process), *The Canadian Engineer*, vol. 40, no. 19, May, 1921, pp. 454-455.
- 12 A Centrifugal Machine for Casting Pipe, *Iron Age*, vol. 98, no. 10, September 7, 1916 (first description of the DeLavaud process).
- 13 Casting Rings in Centrifugal Machine, E. F. Cone, *Iron Age*, vol. 102, no. 14, October 3, 1918, pp. 801-807.
- 14 Centrifugal Castings (The Stokes machines), *Engineering*, vol. 111, no. 2881, March 18, 1921, pp. 311-312.
- 15 English Make Centrifugal Castings, H. Cole Estep (same as the preceding item, but more complete), *Foundry*, vol. 50, no. 6, March 15, 1922, pp. 217-222.
- 16 Control of Centrifugal Casting by Calculation, Robert F. Wood, *Mechanical Engineering*, vol. 43, no. 11, November, 1921, pp. 727-728 and 730.
- 17 Mold Serves as Electric Furnace, E. C. Kreutzberg, *Iron Trade Review*, vol. 49, no. 1, July 7, 1921, pp. 33-35 (description of the electric type of the Cammen process, reprinted in *Foundry*, vol. 49, no. 19, October 1, 1921, pp. 772-774).
- 18 Steel Pipe by the Centrifugal Process, L. Cammen, *Iron Age*, vol. 109, no. 6, February 9, 1922, pp. 405-406 cp. editorial in the same issue, *Progress in Centrifugal Casting*, p. 426).
- 19 Centrifugal Casting, L. Cammen, *Chemical and Metallurgical Engineering*, vol. 26, no. 8, February 22, 1922, pp. 354-358.
- 20 Ledebur, *Handbuch der Eisen- und Stahlgiesserei*, 1892.
- 21 B. Osann, *Eisen- und Stahlgiesserei*, 1920, pp. 423-424.
- 46 The following references apply to special processes:
 - Huth: 7, 21
 - DeLavaud: 11, 12, 13
 - Stokes: 2, 14, 15
 - Millsbaugh: 10
 - Cammen: 17, 18, 19
 - Hume: 8

APPENDIX No. 2

U. S. PATENTS ON CENTRIFUGAL CASTING

47 The following list gives the numbers (which are sufficient to locate the patents) of patents issued by the U. S. Patent Office on centrifugal casting or machines used thereon. So far as a careful search through the records of the Patent Office has been able to establish, these are all that have been issued; in any event, the compiler is confident that no important patents dealing with the art have been omitted. Those desiring to secure copies of the patents should bear in mind that the majority of the earlier patents are out of print and can be obtained only by ordering photostats. Copies of patents which are available can be obtained by writing to the Commissioner of Patents at the regular rate of 10 cents per copy.

1,403,347	1,386,268	1,410,885	1,377,226
1,377,406	1,385,781	1,376,090	1,358,435
1,377,372	1,382,821	1,360,484	1,352,523
1,366,875	1,349,416	1,351,766	1,344,409
1,351,767	1,329,295	1,347,582	1,320,744
1,340,337	1,329,179	1,323,252	1,331,660
1,329,296	1,325,039	1,329,754	1,310,865
1,302,584	1,323,253	1,324,660	1,307,823
1,229,918	1,304,118	1,309,823	1,302,838
1,315,512	1,302,448	1,320,910	1,286,555
1,300,123	1,277,543	1,293,049	1,263,208
1,283,139	1,215,243	1,280,289	1,223,676
1,276,038	1,240,546	1,239,994	1,199,281
1,257,325	1,169,192	1,199,353	1,195,803
1,177,957	1,161,701	1,190,009	1,142,840
1,128,009	1,124,099	1,150,974	1,113,333
1,124,841	1,110,954	1,121,659	1,095,523
1,113,017	1,066,604	1,109,572	1,058,250
1,095,230	1,023,330	1,080,224	1,040,517
1,047,972	1,015,818	1,004,293	1,009,167
1,015,819	986,130	950,106	985,489
964,371	951,614	971,957	930,828
914,459	918,880	893,037	839,861
839,560	777,560	767,928	727,103
655,235	652,756	734,375	743,077
644,926	648,601	644,018	644,019
581,272	550,089	538,835	522,093
510,995	482,405	467,469	462,423
359,484	462,422	444,162	427,708
422,590	412,687	368,746	359,483
348,709	224,245	110,717	104,130
96,911	65,642	48,022	98,673
35,884	24,915	24,539	18,924
5,988			

APPENDIX No. 3

SOME MATHEMATICAL CONSIDERATIONS ON THE SUBJECT OF CENTRIFUGAL CASTING

48 This is not intended to be a complete treatment of the complicated phenomena taking place in centrifugal casting, but merely a somewhat elementary presentation of some of the more important facts that will help in understanding the processes and in estimating the forces acting therein.

49 Centrifugal casting may be carried on with the axis of rotation horizontal, vertical, or inclined, although one may consider the case of casting about the inclined axis as the general case, and the horizontal and vertical positions as special cases at the two limiting extremes. Finally, there is the case, of no apparent practical importance, of casting about axes of double rotation, that is, where, in addition to the rotation of the mold, the entire machine is spun about some axis which may and may not be external to the mold. Practically, such a case would arise if, in addition to spinning the mold, the entire machine were placed on a turntable and given a rapid rotation, say, about some vertical axis. This last case will not be considered here.

CASTING ABOUT A VERTICAL AXIS

50 The case of casting about a vertical axis is the simplest theoretically, and of considerable commercial importance, as nearly all castings of gears, railroad wheels, etc., in which already quite a large production has been built up, are made on a vertical axis.

51 There are several ways of proving that a liquid subjected to rapid rotation about a vertical axis will assume on its inner surface the shape of a paraboloid. Horace Lamb¹ proves it by deriving the common integral of the dynamical equations of the rotating liquid. A simpler proof is offered by Prof. V. L. Karpicheff.²

52 For a particle of liquid m , Fig. 4, on the inner surface of the body formed by the centrifugal force, determine the force mc considered as a resultant of the force of gravity mb and the centrifugal force ma which in its turn is equal to mq^2r where q is the angular velocity of rotation of the vessel.

53 The laws of equilibrium of liquids demand that the surface of the liquid at m be normal to the direction of the force mc , which means that mc must be normal to the curve $AmBC$ at m . Continue this normal until it intersects the axis of rotation, say, at d . Since the triangles mdo and mbc are similar, we have

$$\frac{od}{om} = \frac{mb}{bc} = \frac{mg}{mq^2r}$$

Hence

$$od = \frac{g}{q^2} \dots \dots \dots [1]$$

¹ Hydrodynamics, 1906, p. 24.

² Talks on Mechanics, St. Petersburg, 1907, pp. 94-95.

which proves that the subnormal od to the curve $AmBC$ does not depend on r , and consequently is the same for all points of this curve. But the subnormal is constant only for a parabola. Hence, $AmBC$ is a parabola, and the "funnel" formed by a rotating liquid is a paraboloid of revolution.

54 Lamb (*loc. cit.*, Par. 51) proves also that in a mass of liquid rotating about a vertical axis with constant and uniform angular velocity and only under the action of gravity a velocity-potential cannot exist, from which it follows that a motion of this kind could not be generated in a "perfect" fluid, i.e., in one unable to sustain tangential stress.

55 Hans Lorenz¹ offers a carefully-worked-out proof to the effect that the distance to which the apex of the paraboloid of revolution of the liquid mass

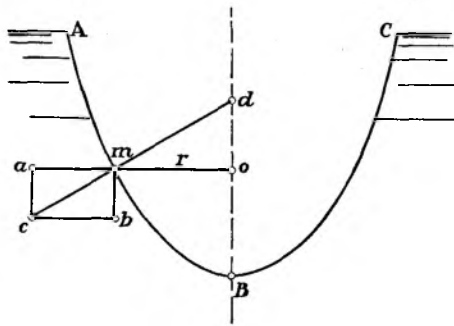

FIG. 4 FORCES ACTING IN A LIQUID IN A VESSEL ROTATING ABOUT A VERTICAL AXIS

rotated about a vertical axis, as referred to above, is depressed, is proportional to the square of the peripheral speed of rotation.

56 The complete derivation of the internal shape of a liquid rotating presumably at a considerable speed about an axis inclined at an angle, α , to the vertical (that is, the direction of acceleration due to gravity) is given by Hans Lorenz, who starts with the equations of motion of the liquid, together with the equation of continuity

$$\frac{\partial(w_r r)}{\partial r} + \frac{\partial(w_z r)}{z} = \frac{\partial w_n}{\partial \phi} = 0. \dots \dots \dots [2]$$

57 He proceeds to make certain substitutions in the equations of motion referred to above. The integration of the equations remains, however, extremely difficult if not impossible. Lorenz therefore assumed that it would be permissible to neglect the axial and radial components and retain only the tangential velocity

$$w_n = \epsilon r \dots \dots \dots [3]$$

where ϵ is the constant angular velocity of rotation.

58 From Fig. 5 he derives

$$q_r^2 + q_n^2 + q_z^2 = g \dots \dots \dots [4]$$

¹ Technische Hydromechanik, 1910, p. 372.

and this together with Equation [3], which, by the way, satisfies the equation of continuity [2], permits him to write

$$\left. \begin{aligned} g \sin \alpha \cos \phi + \epsilon^2 r &= \frac{g}{\gamma} \frac{\partial p}{\partial r} \\ -g \sin \alpha \sin \phi &= \frac{g}{\gamma} \frac{\partial p}{r \partial \phi} \\ g \cos \alpha &= \frac{g}{\gamma} \frac{\partial p}{\partial z} \end{aligned} \right\} \dots \dots \dots [5]$$

59 These Equations are consecutively multiplied by ∂r , $r \partial \phi$, ∂z , added together and integrated, which gives

$$gr \sin \alpha \cos \phi + gz \cos \alpha + \frac{\epsilon^2 r^2}{2} = \frac{g}{\gamma} p + C \dots \dots \dots [6]$$

Next, there is added to both sides the member

$$\frac{g^2 \sin^2 \alpha}{2 \epsilon^2} = \frac{a^2 \epsilon^2}{2}$$

which gives

$$\frac{\epsilon^2}{2} (r^2 + a^2 + 2ar \cos \phi) + gz \cos \alpha = \frac{g}{\gamma} p + C_1 \dots \dots \dots [7]$$

60 Further, the expression

$$r^2 + a^2 + 2ar \cos \phi = \rho^2 \dots \dots \dots [8]$$

defines the direction ρ of an element of liquid located at a distance

$$a = \frac{g \sin \alpha}{\epsilon^2} \dots \dots \dots [9]$$

from a new axis parallel to the original axis but located above it. Because of this, instead of Equation [7], we may write

$$\frac{\epsilon^2 \rho^2}{2} + gz \cos \alpha = \frac{g}{\gamma} p + C_1 \dots \dots \dots [10]$$

61 If this equation be considered with respect to the variables ρ and z at constant pressure, it will be seen that it describes a paraboloid of revolution differing from similar paraboloids of revolution defining the motion of a liquid about a vertical axis, in that in the member containing z we find $g \cos \alpha$ instead of g . Because of this, the distance of the apex of the paraboloid from its topmost edge z_1 is

$$z_1 = \epsilon r_0 \sqrt{\frac{h_1}{g \cos \alpha}} \dots \dots \dots [11]$$

as compared with the distance between the same elements in the case of a rotation about the vertical axis,

$$z_1 = \epsilon r_0 \sqrt{\frac{h_1}{g}} \dots \dots \dots [12]$$

62 A comparison of these equations would indicate that in the case of an inclined axis z_1 increases very rapidly with the speed as the angle of inclination of the axis increases. This leads at once to the derivation of the basic formula for the case of spinning about the horizontal axis:

$$\frac{\epsilon \rho^2}{2} = \frac{g}{\gamma} p + C_1 \dots \dots \dots [13]$$

in accordance with which the surfaces of equal pressure in a liquid rotating about a horizontal axis are of approximately cylindrical shape and their common axis is at a distance, a , over the axis of rotation, a being defined by equation

$$a = \frac{g}{\epsilon^2} \dots \dots \dots [14]$$

CASTING ABOUT A HORIZONTAL AXIS

63 The mathematics of casting about a horizontal axis are essentially extremely simple. The liquid acts practically like the rim of an ideal flywheel, that is, one which either has no arms or arms capable of infinite extension without effecting any pull on the rim.

64 Three forces are acting on the liquid in a horizontally located mold: namely, gravity, friction of the liquid against the wall, and centrifugal force. If there were no friction of the liquid against the wall, the liquid would not be subject to the centrifugal force and the mold would simply spin around it while the liquid would retain its level. It is important to realize this fact, although numerically hitherto no way has been worked out to take into consideration the slip of the liquid except by providing for it in determining the spinning speed. The subject is extremely obscure as yet, because of a total lack of experimental data. Assuming, therefore, that the coefficient of friction between the liquid

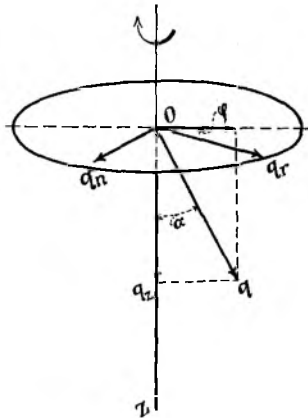

FIG. 5 FORCES ACTING ON A LIQUID IN A VESSEL ROTATING ABOUT AN INCLINED AXIS

and the walls of the mold is such that the liquid moves at the same peripheral speed as the walls of the mold in contact therewith, one may apply to the calculation of the centrifugal speed acting on the liquid the same formula as is applied to the rim of a flywheel, namely,

$$F = 0.000341 WRN^2,$$

where F is the total centrifugal force in pounds, W the weight of the liquid in pounds, R the radius in feet, and N revolutions per minute. Where the thickness of wall of the cast article is small, it is advisable to take the inside radius as R . Where the thickness of the wall is considerable, the mean radius may be taken by adding the inside and outside radius and dividing the sum by two. Finally, where the thickness of the wall is very large and the radius small, it is well to use for R the value of the outside radius, which is, strictly speaking, erroneous, but permissible, as the error lies on the safe side. As a rule, however, the mean radius will give values precise enough for all practical purposes.

65 Experiments have shown that for some metals, certain speeds of rotation have to be maintained, and it would appear that the speeds of rotation that have to be maintained depend partly on the temperature range between the pouring temperature of the metal, its freezing temperature and the temperature of the mold. The speed of rotation also depends to a certain extent on the thickness of wall which has to be cast. Experimentally it has been found that for steel the speed may be expressed as $N = \frac{1675}{\sqrt{r}}$ where r is the inside radius of

the casting in inches. If this value be substituted in the equation for centrifugal stress, it will show that each pound of metal in the casting exerts a centrifugal pressure equal to 75 lb.

66 Essentially, centrifugal pressure does not depend on the specific weight of the metal, a pound of water at a given speed exerting the same centrifugal force as a pound of mercury. Actually, however, it is not quite so, because the value of centrifugal force depends, as seen from the above equation, on R as well as on W . Now, a pound of water occupies 13.6 times as much space as a pound of mercury, which affects the value of the mean radius whether derived by approximation or by formal mathematical methods.

FORCES ACTING ON THE LIQUID IN A HORIZONTAL MOLD IN THE DIRECTION
OF THE AXIS OF THE MOLD

67 From a practical point of view this is an extremely important subject which, as far as the author is aware, has not been yet given due consideration. The importance of this subject lies in the fact that it is the forces acting in a longitudinal direction that permit the metal poured in at one end of the mold to be spread the entire length of the mold, and this in turn permits using a short stationary spout, avoids the use of such complicated and at times unsatisfactory devices as trough spouts, sliding spouts, etc.

68 In order to bring the problem to its simplest elements, it is assumed that the mold is of considerable length, say, 20 ft., of small diameter, say, 4 or 5 in., and is at room temperature, and that the liquid therein is mercury. It is further assumed that the speed at which the mold is spun is such as to satisfy the above equation in such a manner that $F = 75$ lb. when $W = 1$ lb.

69 In Fig. 6A, m is the mold; assume now that while the mold is spinning, a batch of mercury has been poured in so as to form a ring w , 3 in. long and $\frac{1}{2}$ in. in wall thickness; assume further that by some means such a ring has actually been produced, if only for an instant, and that, as the ring begins to spread, new metal is supplied to maintain its shape.

70 Take the droplet of mercury P , Fig. 6B, which shows part of Fig. 6A in an enlarged form. It is acted on by its own centrifugal force equal to $100 F$, where F is its weight. Furthermore, it undergoes a push on the part of the small cylinder a , equal roughly to $100 A$, where A is the weight of the cylinder a . Because of this, the droplet P exerts a pressure on all the droplets around it, and in particular tries to push the droplet C immediately between it and the wall of the spinning vessel and thus displace it in the direction toward the wall. Droplet C does the same thing to the next one back of it, and this process continues until we reach droplet D , which is right next to the wall. This droplet, according to the elementary laws of hydraulics, exerts a pressure which is the same in all directions. The pressure exerted against the wall of the spinning

mold produces in it a stress, but the wall is supposed to be solid enough to resist this stress without appreciable deformation.

71 On the other hand, however, droplet *D* exerts a pressure on droplet *E*, and as there is nothing to hold droplet *E* in its position except friction, which is comparatively slight in this case, droplet *E* moves away in the direction *e*. This leaves droplet *D* unsupported on one side, and as droplet *G* exerts on it the same kind of pressure that it does on *E*, *D* moves into the place of *E*. In this way there is a continual displacement of the droplets in both directions until they encounter a solid wall and a state of rotational equilibrium has been established, which means until a uniform cylinder has been formed from one end of the mold to the other and the supply of new metal has ceased.

72 Let us see now what are the forces that propel the metal and force it to spread in the manner indicated. Assume that the mold is 6 in. inside diameter and that molten steel is poured from the spout at such a rate as to form the ring *w* $\frac{1}{2}$ in. wall thickness and only $\frac{1}{2}$ in. long, instead of 3 in. as shown in Fig. 6. The weight of the metal in the ring is then slightly over 1 lb. per sq. in. of the area of the mold wall covered by metal, and the pressure per sq. in. of

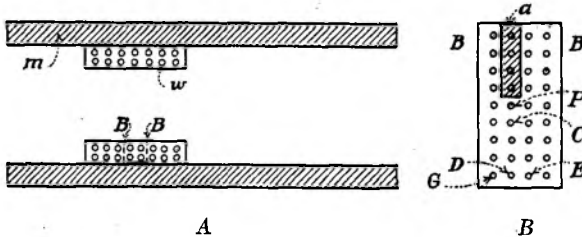

FIG. 6 FORCES CAUSING THE LIQUID IN A VESSEL ROTATING ABOUT A HORIZONTAL AXIS TO SPREAD LONGITUDINALLY

(A, left, mold and ring of liquid; B, right, a part of the ring of liquid in A, magnified)

wall, or which is equivalent to it, per sq. in. of molten metal, is 100 lb. At such a pressure molten steel, having to overcome merely its own friction and the friction against the walls of the molds, ought to make the distance of 20 ft. in something under $\frac{1}{10}$ second.

WHAT PREVENTS THE METAL FROM SPREADING IN A COLD MOLD?

73 Great difficulty has been experienced in getting the metal to spread in a cold or only slightly heated mold, which led to the development of elaborate sliding spouts, trough spouts, and the like. The reason for this difficulty lies in the fact that the above reasoning is correct only for the case of liquids, such as mercury or molten and perfectly fluid metals, as it is only in liquids that the pressure at a point is equal in all directions.

74 But the metal in a cold mold does not stay fully liquid for any appreciable length of time. As the particle *D* is projected beyond the ring *w*, it strikes the cold wall of the mold. The metal film is at that instant so thin that the amount of reserve heat in it is very slight. When this thin film of molten metal comes in contact with the mold, which is say, 2000 deg. colder than the metal, and many times its volume, the metal freezes, and in doing so forms a hard and non-liquid fringe about the ring *w*. This at once tremendously increases

the frictional resistance of the spread of the metal, and in fact creates about the same situation as a dam of rocks in a river bed. The flow is impeded, in addition to which chilling of the metal is assisted by the slower flow.

IS CENTRIFUGAL FORCE A REAL FORCE OR A MATHEMATICAL FICTION ?

75 This question has been asked several times and is due to the fact that, notwithstanding its great importance in mechanical engineering, the subject of centrifugal force in our textbooks of physics is considered in a very cursory and superficial manner. On the one hand, every engineer knows that there is some force that produces effects ascribed to what is called centrifugal force. On the other hand, however, an incorrectly understood theory of the action of this force makes the subject a good deal more mysterious than it needs to be. Here is how the matter appears from a cursory reading of our textbooks on physics. Let us assume that a ball attached to a string is whirled about a fixed center. Then, the mass m of the ball moves in a circle owing to the tension in the string which pulls the ball toward the center. This is the centripetal force, the magnitude of which is equal to the mass m times the acceleration, or $\frac{mv^2}{r}$, where v is the uniform circular speed and r the radius of the circle. Because of the action of this force the initial motion instead of being rectilinear becomes circular. Thus far everything is clear, but from now on a misunderstanding is apt to arise.

76 Assume that in addition to the centripetal force, a centrifugal force acts on the body m and our textbooks usually state that the centrifugal force is equal in magnitude and opposite in direction to the centripetal force. Since however, the two forces are equal in magnitude and opposite in direction they ought to cancel each other, so that if it be assumed under the above reasoning that the centrifugal force is a real force and not a mathematical fiction, it would mean that no force is acting on the ball as the two forces, which we have assumed to be active, mutually cancel. But if that were the case, there would have been no reason why the ball should not follow the rectilinear motion, and yet, instead of doing that, it moves in a circle. There is, therefore, a contradiction apparently created by the assumption that centrifugal force is a real force.

77 The error in this reasoning lies in the imperfect understanding of the action of the two forces and more precisely in the erroneous assumption that both forces, — the centripetal and centrifugal, — act on the same body, namely, the ball.

78 Actually, however, we have here a system consisting of *two* bodies — the ball and the string. The action of the string on the body is due to centripetal force, while the reaction of the body on the string is due to the centrifugal force, the action and reaction here as elsewhere being equal and opposite in accordance with the third law of Newton.

79 Centrifugal force is therefore a perfectly real force and may be measured by a dynamometer placed in the string. The centripetal force is also a perfectly real force, though there does not appear as yet to be any way of directly measuring it, nor is any necessary as it can be determined by measuring the centrifugal force and changing the sign of direction.

APPENDIX No. 4

TEMPERATURE CONTROL IN CASTING AND MOLD

80 The purpose of temperature control of the metal of the casting and of the mold is to give time to the metal to get rid of its occluded gases and slag, which, *if time is available*, is powerfully assisted by the action of centrifugal force, and also to give time to supply hot metal to contraction cavities formed during the early stages of the cooling of the metal. This has been more fully explained in Pars. 16-20. The matter is of such importance that it is no exaggeration to say that if, in centrifugal casting, you take care of the mold, the metal will take care of itself.

81 The above brief exposition of the purposes of temperature control in centrifugal casting provides us at once with a criterion as to the proper temperature of the mold at the time of pouring the metal. We have to give time to the metal to perform certain functions which it can perform only while it is still liquid, and this means that the mold must be at such a temperature that the metal of a given casting, while in contact with the mold, should remain fluid for the necessary length of time. This, in formal language, may be expressed as follows: The temperature of the mold should be such that the loss of heat from the metal to the mold at its obtaining temperature be less than that which is sufficient to chill the metal to the point of congelation within the time period necessary for the formation of the proper casting shape and for the escape of the gases from the metal.

82 The following calculation may help to illustrate the application of the above broad principle. It is assumed that a metal mold is used to make a steel pipe, say, 6 in. in diameter and of standard thickness (0.280 in. wall, say, 20 lb. per ft.). Experimentally it has been established that for casting such a size, the metal should remain fluid after pouring for a period of not less than, say, 30 sec. Assume that the metal, when coming out of the ladle, has a temperature of, say, 2800 deg. fahr., which is probably higher than it will actually have in an open-hearth plant. Even with this temperature, the metal has, between the liquid and solid states, a reserve range of only 300 deg., equivalent to about 650 B.t.u., neglecting latent heat.

83 The reserve heat is here so low that if a mold of conventional type were used at a temperature of, say, 400 deg. fahr., the loss of heat to the mold would have been so rapid that the metal of the casting would freeze in not more than a couple of seconds, as has been proved by actual experiment. An extremely hot mold therefore becomes necessary, and tests have shown that to obtain good castings, one must have the mold at bright white heat, or 1800 to 2000 deg. fahr. Furthermore, it is desirable not to have the mold made of a metal that is a very good conductor of heat, as the prime function of the mold is to conserve the heat in the casting, and not to carry it away.

84 On the other hand, however, where a metal mold is used, unless such metals as cast tungsten are available, which is not yet the case, there is a certain

limit to the temperature that the mold itself will stand without collapsing under the combined action of temperature and centrifugal stresses. It would appear that chrome-nickel alloys can stand temperatures as high as 2200 deg., possibly 2300 deg. fahr. for a considerable number of castings. This gives us at once a basis for calculating the size of the mold as affected by temperature conditions. (The question of stresses has also to be considered, cp. Appendix No. 5.)

85 Taking again the above example of a 6-in. standard pipe, we see that it weighs 20 lb. per foot, and is cast at a temperature of 2800 deg., while it is specified that the mold should not be heated to a temperature above 2200 deg. after starting with an initial temperature of 2000 deg. The weight of the mold must therefore be such that it could absorb all the heat in the metal down to the point of temperature equilibrium (2200 deg. fahr.) without exceeding its own limit of safety. Assume that the specific heats of the mold and metal of the casting are equal, and that the weight of the mold per foot of casting is X . Then

$$X = \frac{20(2800 - 2200)}{(2200 - 2000)} = \frac{20 \times 600}{200} = 60 \text{ lb.}$$

86 The following has to be taken into consideration before we can accept this figure definitely. The heat taken up by the mold from the casting is only partly retained by it, causing it to rise in temperature; it is partly dissipated to the surrounding air, gibs, barrel and foundations of the spinning machine (which, by the way, have to be sufficiently massive to be able to do this without becoming excessively hot). It is well, however, to neglect this factor, in determining the size of the mold, and to treat the fact of the loss of heat from the mold to the ambient medium merely as a factor of safety. Under these conditions, and taking into consideration temperature conditions alone, it is perfectly safe to make the mold of a weight equal to $1.5X$, or say 90 lb. per foot. (Actually, 100 lb. per foot has been found desirable, to take care of stresses.)

87 Suppose now that instead of casting a pipe of standard thickness, 0.280 in., it is desired to cast a cylinder with walls 1 in. thick. Such a cylinder weighs roughly 53 lb. per foot, as compared with 20 lb. for standard pipe. Accordingly, it contains more than 2.5 times as much heat above the point of solidification as did the former casting, and, because of this, does not chill quite as easily. As a result, it does not need to have the mold quite as hot as in the former case, and, as a matter of fact, a mold at 1200 to 1500 deg. fahr. will handle this kind of casting very well. The same mold as above is therefore applicable. It will be noted that in all cases a range of temperatures is indicated, rather than a single figure. This is due to the fact that in determining the temperature to which the mold has to be heated, factors in addition to those discussed above have to be taken into consideration, e.g., the length of the casting which affects the proportion of end losses to the total heat losses from the casting; the heat conductivity of the metal of the mold; the character of the material used for floating the mold, etc.

88 The underlying purpose of heat control is, however, the same in all cases, and that is, to give the metal time to clear itself of gases, and to have the freezing proceed at such a rate as to fill up contraction cavities with good molten metal. To do this, the mold has to be heated to the proper temperature, and if the mold and metal are at the proper temperature, there is no reason why a good casting should not be obtained *every time*.

89 The above does not, however, exhaust the subject of heat control, and applies only to metals which are not adversely affected by slow cooling from the liquid state. Bronze is one of the metals that are, and when such metals have to be cast centrifugally, especially in fairly thick sections ($\frac{3}{4}$ in. and up), the control of temperature has to be exercised during a much longer period than, e.g., with steel or monel metal. The first period, that is pouring and, say, 30 to 45 seconds thereafter, is governed by the same laws as have been discussed above, i.e. the temperature of the mold is held initially at such a level as to permit the metal to throw out the gases and slags, and to form the first dense layer directly against the mold wall. If, however, the same conditions were maintained throughout the rest of the cooling process, the latter would be very slow, and there is danger that the grain of the metal would be coarse and the casting unsatisfactory. It is therefore necessary to cast the metal hot and against a hot mold, but, after the tube has been formed, to chill it rapidly.

90 Some makers of centrifugally cast articles of bronze and pure copper have attempted to meet these requirements by squirting water through a hose onto the casting after it has been poured and had a chance to spin up. Good results have been obtained where the casting is short, less satisfactory with long castings. One does not have to look far for the reason of this discrepancy. In centrifugal casting there is a tendency, due to the action of the centrifugal force, to force the metal from the inner wall to the outer wall. Therefore the freezing of the metal should proceed from the outside inward, the inner molten metal supplying material for filling up contraction cavities. In short casting, the stream of water cools the mold as fast as, and possibly faster than, the metal of the casting. In long castings, however, 15 ft. and up, the water has no chance to cool the mold, with the result that the inner wall freezes first, which is contrary to what should take place in order to make a good casting. The lack of proper control of the cooling process in bronze castings leads to uncertainty of results which is possibly the explanation of the fact that some of the present manufacturers refuse to sell rough castings: not being certain as to what the state of the metal would be found to be after machining, they prefer to scrap bad castings themselves rather than have their customers do it. This may be good business policy, but indicates a rather primitive state of engineering.

91 In the Cammen process a special type of machine is used in which the mold is heated previous to casting (for common bronze, to about 1400 deg.), and then, at the proper time (which depends mainly on the size of the casting), is cooled by a stream of water. With such an arrangement, the cooling of the casting proceeds from the outer walls inward, as it should, and means are available to insure uniformity of results. Iron is probably the best metal that can be used for the mold, and it is expected that a cheap way to make such mold will be afforded by the Le Fer or Eustis method of electrolytically depositing 99.9 per cent pure iron in the form of pipes over a rotating mandrel, a good illustration of how one discovery helps another.

APPENDIX No. 5

STRESSES IN MOLDS IN MACHINES FOR CENTRIFUGAL CASTING

92 The subject of stresses in molds of machines for centrifugal casting is particularly important in large machines and in all machines using a hot mold, in the former because of the great numerical value of these stresses, and in the latter because of the low strength of materials at temperature of the order of 2000 deg. fahr.

93 These stresses depend primarily on the method of supporting the mold in the spinning bench. There are always present stresses:

a What might be called fluid-pressure stress, or the stress exerted by the liquid metal of the casting, and

b Flywheel stress, or the stress induced in the mold itself due to its rotation, and which would have been present even if it were spun empty. In addition to this, however, in a mold supported at intervals, there are present what might be called crankshaft stresses, stresses of bending essentially analogous to those induced in a crankshaft similarly supported. There are also gyroscopic stresses, the numerical value of which is, however, small as compared with the other three kinds.

94 The value of the crankshaft stresses is a matter of considerable importance, particularly as the deformations produced by these stresses are cumulative. For permanent molds in machines for centrifugal casting, materials have to be used which have a fairly low elastic limit, and this elastic limit is especially low at high temperature. Deformations produced in the course of spinning acquire, therefore, as a rule, the character of permanent sets, and as such affect the dynamic balance of the rotating parts, causing an unbalance which tends to increase the local stressing of the material, and this, in its turn, tends to increase the deformation. As the process is cumulative, it may, in the final end, lead to rapid destruction of the mold, and if not guarded against by proper caution, to accidents. It is therefore highly desirable, especially with hot molds, to avoid constructions in which crankshaft stresses may arise. The methods of calculation of these stresses are not given here, as they do not differ from those used by designers of steam turbines, with the exception of the fact that the bending strength of the material is very low as compared with the stress imposed.

FLUID-PRESSURE STRESSES

95 The stress produced by the molten metal in the mold of a machine for centrifugal casting is exactly of the type shown in Fig. 1 of the paper of Prof. Reid P. Stewart in the TRANSACTIONS of The American Society of Mechanical Engineers, vol. 34, 1912, p. 298.

96 The designer of a mold for a centrifugal casting machine is usually interested in selecting a safe thickness of wall for a given casting. As the size of the casting is given, the inside diameter of the mold is determined. Further-

more, as will be seen clearer later, the stress per square inch of the wall of the mold is also determined by the data of the problem. There is a certain leeway as to the permissible fiber stress in the material of the mold, if there are several materials to choose from, but once the material is selected and the temperature at which the mold is to be used is established, the fiber stress is also settled and all that remains is to determine the thickness of the wall of the mold.

97 For this purpose one of two formulas may be used, namely, the common formula

$$t = \frac{\frac{1}{2}Dp}{f} \dots \dots \dots [15]$$

or the Barlow formula

$$t = \frac{1}{2} \frac{D'p}{f} \dots \dots \dots [16]$$

where t is the thickness of wall in inches, D the inside diameter in inches, D' the outside diameter in inches, p the internal gage pressure in lb. per sq. in., and f the permissible fiber stress in the wall in lb. per sq. in.

98 The "gage pressure" p of the Barlow formula is derived for centrifugal casting as follows. Assume that the casting has an external diameter D and an internal diameter d ; the weight of a ring, 1 inch wide, is then $W = k(D^2 - d^2)$, where k is a constant (0.220 for steel; 0.204 for cast iron; 0.235 for brass; 0.252 for copper, etc.). But, in spinning, each pound of metal generates a centrifugal force determined by the various elements discussed in Appendix No. 3, primarily number of revolutions and radius of spinning, so that each pound of metal in the casting exerts on the mold a force equal to M lb., and hence on a ring of the mold, 1 inch wide, there is exerted a pressure MW lb.; hence, the "gage pressure" or pressure per sq. in. p is $\frac{MW}{\pi D}$ where D is the inside diameter of the mold in inches.

99 The difference between the common formula [15] and the Barlow formula [16] is that the first is expressed in terms of the inside diameter D and the second in terms of the outside diameter D' . Barlow's formula is preferable because it is on the side of safety. On the other hand, however, it cannot be used directly in this case because it begs the question. As shown by the above method of calculating p , it contains the value of the inside diameter D . Therefore if D' , which is the outside diameter, were known, it would not be necessary to resort to either the Barlow or the common formula, as t could be obtained by simply subtracting the inside diameter from the outside and dividing the result by two. This does not prevent one from using the Barlow formula on condition, however, that it be expressed in a way slightly different from the usual, namely,

$$t = \frac{1}{2} \frac{p}{f}(D + 2t) \dots \dots \dots [17]$$

100 The meaning of either t or f in this formula should be very clearly understood; t means the thickness of the cylinder in which the highest permissible fiber stress is f that would withstand the pressure exerted by the centrifugal action of the molten metal on the mold under the assumption that the mold itself is not subject to centrifugal stresses of its own. In other words, t is that amount by which the thickness of the wall of the mold has to be increased in order to take care of the stress produced by the presence of the metal.

101 The meaning of t and f can be presented otherwise: t is the value of the thickness of the wall of the mold having a permissible fiber stress f which

the mold would have had if it had no mass of its own. Since, however, it has a mass and since, in usual practice, the weight of the mold considerably exceeds the weight of the casting, the stresses induced by the rotation of the mold itself have to be considered. These are what has been denoted by the term "fly-wheel stresses."

FLYWHEEL STRESSES

102 If the mold were running empty, that is, without any molten metal in it, it would act practically like an ideal flywheel, that is, a flywheel of considerable length having only a rim but without any arms.

Let w = weight of rim per inch of length in lb.

x = mean radius of rim in in.

N = revolutions per minute

then the centrifugal force acting on the entire rim which is here assumed to be one inch long is

$$P = 0.000341 \frac{wxN^2}{12} \dots \dots \dots [18]$$

103 This is the familiar formula expressed, however, in inches of radius instead of feet.

104 The same formula may be expressed, as follows:

$$P = 0.000014 wD''N^2 \dots \dots \dots [19]$$

where P is the total centrifugal force on the rim and D'' is the diameter in inches.

105 The question now is which diameter to take. In flywheels the thickness of the wall T is very small as compared with the diameter, and therefore the mean diameter or mean radius can be taken for purposes of calculation without introducing a greater degree of inexactness than is carried by the formula itself. In molds for machines for centrifugal casting the situation, however, is very different in this respect, the thickness of the wall being very appreciable as compared with the diameter. Therefore it would not be safe to take the mean diameter, and following the practice of the Barlow formula, the outside diameter should be here taken. On the other hand, however, this would introduce the same difficulty as to the expression of T as has been encountered in considering the fluid pressure stresses. Therefore P may be here expressed as follows:

$$P = KwN^2(D + 2T) \dots \dots \dots [20]$$

where T is the thickness of the rim of the flywheel, as yet irrespective of the stresses induced therein, and $K = 0.000014$.

106 This is the total stress on a section of the mold one inch long treated as a flywheel, that is, running empty. In accordance with the usual processes, it is necessary to divide this by 6.28 to obtain the strain on the cross-section of the mold, in this case equal to T sq. in., and this gives $0.0000023 N^2w(D + 2T)$, which could be written as $Sw(D + 2T)$ where $S = 0.0000023N^2$.

107 From this it would be possible to calculate the value of T , provided the fiber stress f is either known or assumed, since $Tf = Sw(D + 2T)$.

108 At a glance the total thickness of the mold could be obtained by adding T , as derived above, to t as derived in the preceding discussion of the fluid pressure. Actually, however, the value thus obtained would be smaller than the true value of stresses, because the part of the wall equal to t has centrifugal stresses of its own induced in it. Because of this, it is simpler to use a different method based on the following.

109 In the discussion of fluid pressure it was found that the total pressure produced by the fluid metal on a ring cut out of the mold one inch long is equal to WM pounds. This entire strain has to be taken up by the mold in the same way as centrifugal rim stresses are in a flywheel, which means that the strain induced is $\frac{WM}{6.28}$ which may be written as sWM . Hence the total strain

$$P' = T'f = Sw(D + 2T') + sWM \dots \dots \dots [21]$$

where T' is the thickness of the mold sufficient to take up both the fluid pressure and the flywheel stresses, and f , as before, the highest permissible fiber stress in pounds per square inch. From this equations for either T' or f are derived.

$$T' = \frac{SwD + sWM}{f - 2Sw} \dots \dots \dots [22]$$

$$f = \frac{Sw(D + 2T') + sWM}{T'} \dots \dots \dots [23]$$

110 It should be noted in this connection that T' errs here on the side of safety, the entire material of both the mold and the casting being assumed as concentrated on the outside diameter of the mold rather than being distributed between the outside diameter of the mold and the inside diameter of the casting. This may introduce an error as high as 20 per cent. Since, however, this error is on the side of safety, it is not objectionable.

THEMAL-EXPANSION STRESSES

111 As the molten metal is pouring into the mold, the inner wall of the mold is rapidly heated up, and it takes a certain amount of time for the heat to spread throughout the metal and for the temperature of the various parts of the mold to become equalized. This time depends on the heat conductivity of the material of the mold, and in very thick molds may be sufficiently appreciable to induce thermal stresses in the mold, due to more rapid expansion of the inner wall of the mold than of the outer wall of the mold. While it is possible to compute these stresses by using the process developed some fifty years ago by Lord Kelvin for calculating the flow of heat in cylindrical bodies, the experimental data are not sufficient to obtain results that would be valuable in practice and these kinds of strains have to be simply assumed and taken care of in selecting the value for the highest permissible fiber stress, f . This is also one of the reasons why a process for estimating T' has been selected in such a way as to admit of a considerable error on the side of safety.

SPLIT MOLDS

112 If split molds are to be used it is obvious that the entire stress P' is taken up not by the wall of the mold, but by the elements holding the mold together such as bolts, or lugs and dovetails, if the construction shown in Fig. 4 is used. It is obvious that in such a case the thread of the bolts or the side lugs are in shear, the unit value of the shear being $\frac{P'}{h}$, where h is the number of the bolts or lugs that hold the mold together.

DISCUSSION

JAMES B. LADD. The writer has read the paper on centrifugal casting with unusual interest because he has devoted considerable time to the subject, and he feels sure that it will be appreciated by all who are interested in this line of engineering.

The writer believes that most readers of this paper, engineers as well as others, will get the impression that successful centrifugal casting, that is commercial centrifugal casting, can easily be accomplished, and he therefore regrets that the author does not emphasize the fact that it is an exceedingly difficult process to perfect, as is evidenced by the fact that it has been known for more than a century yet not developed on a commercial scale until quite recently, although it has received much attention in this country alone, as is shown by the 135 United States patents listed in Appendix No. 2.

This refers, of course, to the centrifugal casting of ferrous pipes and tubes to which the greater part of the paper is devoted, as the centrifugal process is appreciably less difficult for hollow castings of relatively short lengths and for non-ferrous metals.

It is stated in Par. 42 that "notwithstanding the great simplicity of the machinery and methods of centrifugal casting, it should be clearly remembered that even the slightest imperfections in the design or operation will immediately show up in the casting," but this comes so late in the paper that it may not correct the impression received by readers from several preceding paragraphs, especially Par. 3, which states in part "there is no reason why any good engineer could not design and operate a successful casting machine," which of course means a centrifugal casting machine.

While some of the difficulties to be encountered in developing a centrifugal process commercially are stated in this paper, the writer feels that such difficulties are not sufficiently emphasized and that it should be clearly stated that no engineer should undertake to develop a centrifugal casting process without knowing in advance that he should not expect commercial results without the expenditure of much time and much money. Further, that he should not only become familiar with the patent situation, as

the author states, but that he should also carefully watch the patent situation, because, even if he should get satisfactory results, he is likely to find that he has been antedated in essential details, not only by issued patents but also by unissued patents.

That difficulties are to be encountered in developing a centrifugal process is well illustrated by the history of the making of cast-iron pipe, which was made by the centrifugal process as early as about 1850, and yet the de Lavaud process of making cast-iron pipe was not perfected commercially until a few years ago, and it stands alone today as the only centrifugal process that makes cast-iron pipe commercially.

The term "commercial process" is used as defining a process which produced a product at a cost not greater than the cost of the same product of equal quality produced by other processes. In this connection it is interesting to note that a commercially perfected centrifugal process not only produces a product competitive in cost and quality with like products by other processes, but that usually the centrifugal product is of superior quality. Thus, in the case of the de Lavaud process cited by the author, the strength of the iron in the pipe is greatly increased over the strength of the same iron in pipes cast in sand by the usual foundry method. The author gives this increase in strength conservatively as about 15 per cent, but the writer believes that it is more nearly 40 or 50 per cent.

From Par. 20 the writer understands that the "Cammen process" is one for making steel pipe and tubes in highly heated centrifugal molds. If, as related in Par. 21, this process involves the removal of the castings and the molds from the centrifugal machine at "a temperature well above a white heat," the writer fears that it is likely to be disappointing, as it is difficult to keep hot molds in perfect running condition without removing them from the machine, and the difficulties will be increased if the molds must be handled when hot.

The statement in Par. 7 that a permanent mold is the only practical way of producing pipe on a tonnage basis indicates that the author, like others, has experienced the difficulties inherent to molds lined with sand, which difficulties include the handling of the molds to and from the centrifugal machine and the necessity of using a large number of molds for quantity production, and yet the "Cammen process" includes handling *white-hot molds*.

The description of the method of operation of the Cammen process given in Par. 21 starts with the castings within the molds and omits entirely to describe how the metal is introduced into the mold, but Par. 67 seems to indicate that the metal is poured in at one end of the mold and is spread the entire length of the mold by centrifugal force.

If the metal is poured in at one end of the mold, it is not surprising that he considers it advisable to heat the mold highly. The writer believes that satisfactory results are to be obtained with less highly heated molds by using a moving runner and distributing the metal throughout the mold by the de Lavaud process.

W. M. CORSE. The contribution of such a complete paper marks a distinct step in advance in the recording of the art of this very important commercial process. The author has not only given the history of this process but has described many of its salient features in detail. It seems to the writer that we should be interested in centrifugal casting because it is so practical commercially. The speed of production far exceeds that of the ordinary sand-molding method and the quality of the casting is very superior to any casting that it is possible to produce by the sand-molding method. As the author says, there have been persistent efforts to keep out of the literature information on this process. With all the facts given it becomes evident that obstructive tactics on the part of any manufacturer of centrifugal castings is not only a commercial error but also an error in judging the present state of the art. The author has done the manufacturing industry a service by accumulating so much information regarding the early history of this process as described in Par. 3, namely: "It would appear, therefore, that with the exception of minor details and one or two features in special casting processes there is no reason why any good engineer could not design and operate a successful casting machine with a non-heated or non-cooled mold without running into legal complications." This statement should set straight the minds of many people who have been interested in this subject.

THE AUTHOR appreciates fully the weight of the remarks of Mr. Ladd. It is no doubt true that a great deal of knowledge is necessary for successfully designing centrifugal casting machinery and when the writer stated in Par. 3 that there is no reason why

any good engineer could not design and operate a successful casting machine he had reference only to the patent situation and not to its engineering features.

At the same time, it is well not to exaggerate the difficulties of designing such machines. Thus, excellent machines have been designed and operated by the engineers of the Brooklyn Navy Yard with only a very moderate amount of preliminary experimental work.

As regards Mr. Ladd's remarks as to the great difficulty of handling white hot centrifugal molds, the writer wishes to state that he did not find any trouble in this connection, which he ascribes to proper design of the molds and especially to the use of proper materials. Had the molds been made of cast iron or ordinary steel they would, of course, fly to pieces at the first spinning, but they stand up very well when made of proper alloys. Also, the molds must be properly supported in handling, a problem which has been solved without much trouble. As regards Mr. Ladd's fears that the Cammen process "is likely to be disappointing" because of the difficulty of keeping the hot molds in perfect running condition, etc., it may now be stated that actual experience has shown that such fears are entirely without foundation.

As far as the writer is aware the De Lavaud process has not been used for steel, and, in fact, it is doubtful if it could be so used. Neither does it seem applicable to such metals as monel, nickel and chrome-nickel alloys, where the pouring must be extremely rapid and effected at temperatures of the order of 3000 deg. fahr. No trouble has been experienced with such castings in properly preheated molds.